

# SKSSV3011MT

## SINGLE WALL OVEN WITH STEAM-COMBI, TRANSITIONAL DESIGN

**SIGNATURE**  
KITCHEN SUITE



reddot winner 2024  
best of the best

### GOURMET AI™ & WI-FI ENABLED

Innovative Gourmet AI™ technology<sup>1</sup> identifies your food and automatically makes 10 delicious recipe suggestions.<sup>2</sup> The high-definition Gourmet AI™ Camera allows you to remotely view inside the cavity in real-time via your smart device, record time-lapses, take pictures and even share them online.<sup>3</sup>

### STEAM-COMBI CONVECTION OVEN

Versatile oven combines steam and convection cooking for gourmet results. The convection system cooks food quickly and evenly while steam helps to preserve texture, appearance and taste.

### STEAM SOUS VIDE COOKING MODE

Enjoy sous vide results right in the spacious oven, without preheating. Achieve delicious results that are moist and tender on the inside, crisp and flaky on the outside, all with minimal effort.

### SPEED-CLEAN™

Makes fast work of cleaning a lightly-soiled oven with just a ten minute cycle, using only water.

### AIR FRY

Air Fry crunchy favorites like hors d'oeuvres, wings, fries and more while saving counter space. High temperatures and the convection fan work together to deliver the flavor and crunch you crave with little to no oil.

### Innovation

Wi-Fi Enabled for ThinQ® Control with iPhone / Android App	Yes
ThinQ Care	Yes
ThinQ UP	Yes
Voice Control	Yes (Google Assistant, Amazon Alexa)
Scan-to-Cook	Yes
Smart Recipe (3rd Party Apps)	Yes (Sidechef)
Gourmet AI™ Camera	Yes
Gourmet AI™ Features	
Menu Recommendation, RealTime View Monitoring (Snapshot), Cook Record	
Remote Operation	Yes
Smart Diagnosis	Yes

### Style

Color	Satin Stainless Steel
Handle Design	Transitional
Door Feature	InstaView® Window
GlideShut™ Door	Yes

### Oven Features & Performance

Oven Type	Steam-Combi Convection
Capacity	4.7 cu. ft.
Cooking Modes	
Convection Bake, Convection Roast, Bake, Broil, Steam Cook (Steam-Combi, Steam Sous Vide), Warm, Proof, My Recipe, RapidHeat Roast+, Auto Cook, Air Fry	
Interior Color	Blue
Oven Cleaning	Self Cleaning & Speed-Clean™

<sup>1</sup>Wi-Fi connection and loading the ThinQ® app on a smart device is required to access Gourmet AI™ feature. <sup>2</sup>Recipe suggestion is made from pre-loaded 80 Auto Cook recipes. Keep camera lens and oven door clean and free of obstruction. Accuracy may vary based on usage conditions. <sup>3</sup>Signal may vary depending on Wi-Fi connection. Time-lapse videos are available in 5/10/20 seconds increments and will be captured starting at least 4 minutes into the cook time. Time-lapse videos are stored for 72 hours, and up to 10 videos can be stored at once.

© 2024 Signature Kitchen Suite. All rights reserved. Design, features and specifications are subject to change without notice. Specifications are for planning purposes only. Consult the product's installation instructions for final dimensional data and other details prior to making cutouts or custom panels. Consult with a heating and ventilation engineer for your specific ventilation requirements. Non-metric weights and measurements are approximate. Smart features require Internet access.

1-855-790-6655 | [www.signaturekitchensuite.com](http://www.signaturekitchensuite.com)

**SKSSV3011MT**  
**SINGLE WALL OVEN WITH STEAM-COMBI,**  
**TRANSITIONAL DESIGN**

**Oven Features & Performance (Continued)**

Variable Cleaning Time	Self Cleaning (3,4,5 hrs), Speed-Clean™ (10 min.)
Variable Broil	Yes (Full,Center / High,Med,Low)
Broil Element	2,900 W / 1,500 W
Bake Element	2,500 W
Steam Element	1,960 W
Oven Racks	2 Gliding, 1 Heavy Duty
Rack Positions	5
Oven Meat Probe	Yes
Automatic Shut Off (After 12 hrs.)	Yes
Star-K Certified Sabbath Mode	Yes
Interior Oven Lights (Auto & Manual)	4 LED, 2 Halogen
Convection System	True Convection
Convection Conversion	Yes
Convection Element	2,000 W
Proof	Yes
Variable Warm	Yes (High: 200°F, Med: 170°F, Low: 140°F)

**Controls**

Oven Controls & Display	7 Inch TFT LCD Touch Screen
Electronic Clock & Timer	Yes
Lock Out Function	Yes
Delay Start Time	Yes
My Recipe Menu	40
Preheat Alarm Light	Yes
Audible Preheat Signal	Yes
Cooking Complete Reminder	Yes (Mute, Low, High)
Temperature Display (F or C)	Yes
Language Options	English, Spanish, French
Smart Function	Wi-Fi / Smart Buzzer

**Technical Specs**

Rating (240V / 208V)	6.1 kW / 4.6 kW
Required Power Supply	240V / 208V, 30 Amp

**Dimensions and Weight**

Overall Width (inches)	29 3/4
Overall Depth Including Door (inches)	24 5/8
Overall Depth Including Handle (inches)	26 7/8
Overall Depth with Door Open (inches)	45 5/8
Overall Height (inches)	29 7/16
Size of Water Tank	1 Liter
Net Weight (approx.)	154 lbs
Shipping Weight (approx.)	169 lbs

**Accessories**

Included Accessories  
 Broiler Pan, Grid, Meat Probe, Heavy Duty Rack, Offset Rack, 2 Gliding Racks, Air Fry Rack

**Warranty Summary\***

Limited Warranty, Parts & Labor	3 Years
---------------------------------	---------

\*These warranties give you specific legal rights and you may have other rights that vary from state to state. For complete warranty details, refer to your Use & Care manual.

# SKSSV3011MT

## SINGLE WALL OVEN WITH STEAM-COMBI, TRANSITIONAL DESIGN

### PRODUCT DIMENSIONS

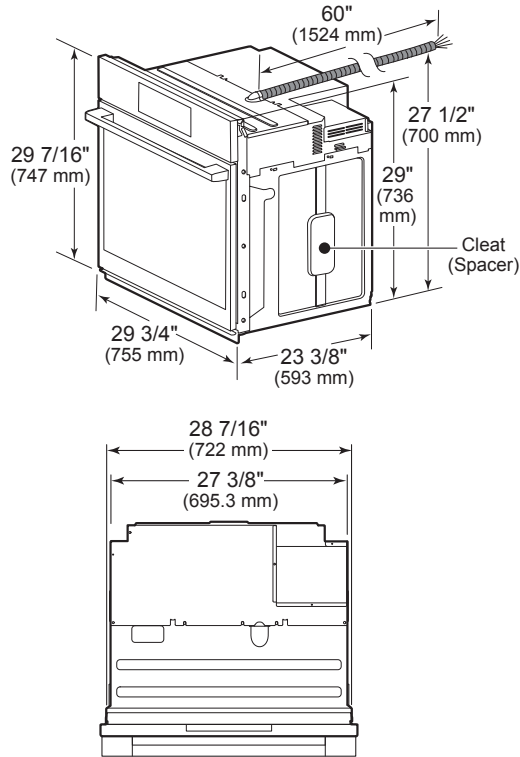

### CUTOUT DIMENSIONS – PROUD INSTALLATION IN WALL CABINET

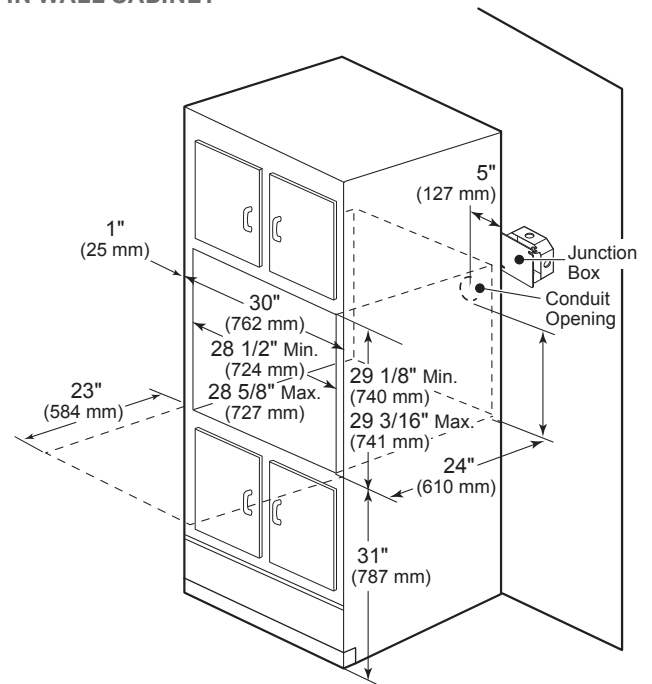

### CUTOUT DIMENSIONS – UNDER-COUNTER PROUD INSTALLATION

Gas or electric cooktops may be installed over this oven.  
See cooktop installation instructions for cutout size.  
See label on top of oven for approved cooktop models.

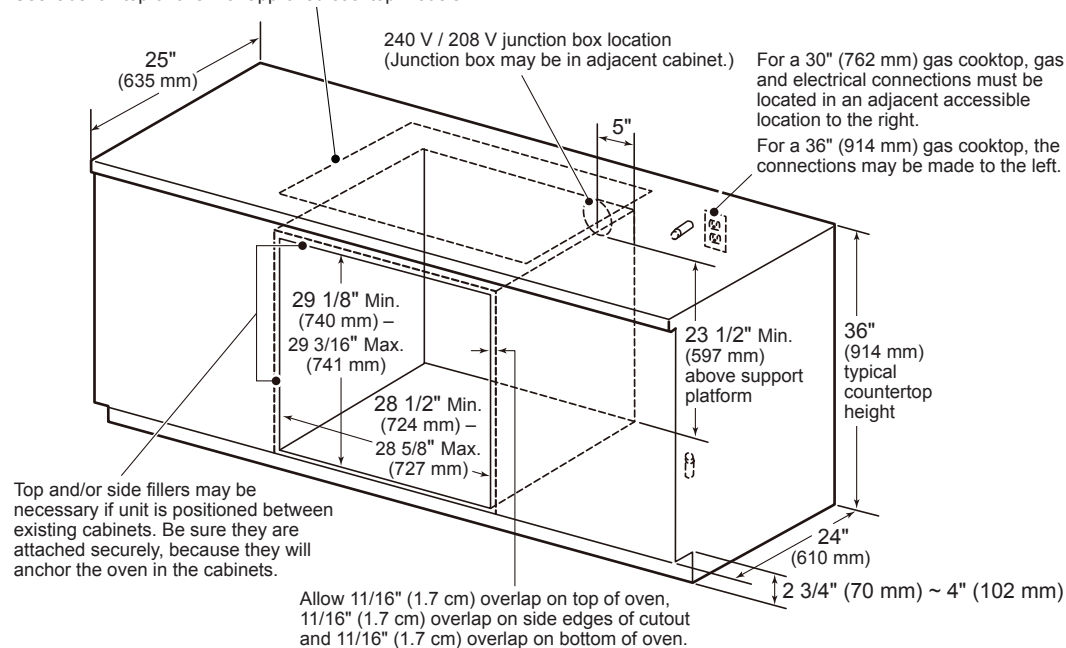

**SKSSV3011MT**  
**SINGLE WALL OVEN WITH STEAM-COMBI,**  
**TRANSITIONAL DESIGN**

**CUTOUT DIMENSIONS – FLUSH INSTALLATION IN WALL CABINET**

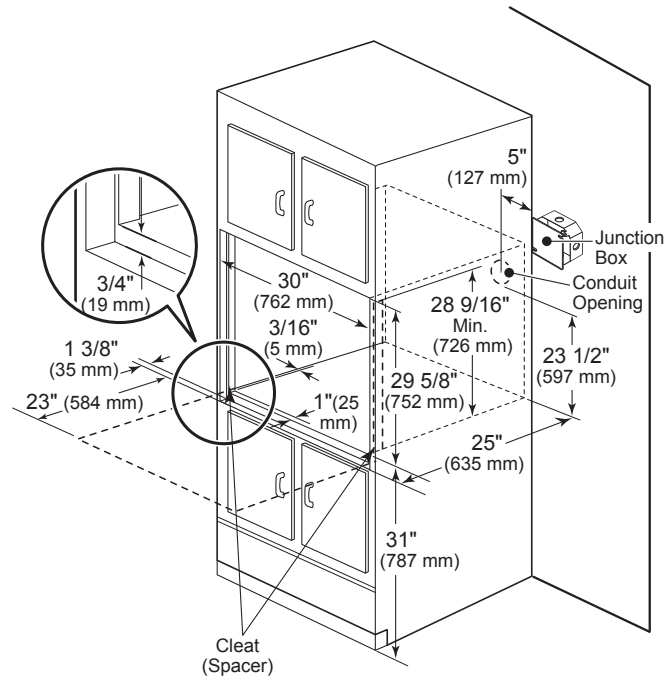

**CUTOUT DIMENSIONS – UNDER-COUNTER FLUSH INSTALLATION**

Gas or electric cooktops may be installed over this oven.  
 See cooktop installation instructions for cutout size.  
 See label on top of oven for approved cooktop models.

