

# SKSIT3001GE

## 30-INCH

### FLEX INDUCTION COOKTOP



#### POWERFUL CENTER ELEMENT

For the ultimate performance the 30-inch cooktop features an industry leading 5,700 watt strong and 11-inch wide center dual element.

#### ONE FLEX COOKING ZONE

From a small pan to a large griddle, the Flex Cooking Zone combines elements to accommodate different sizes and shapes of cookware.

#### PROUD/FLUSH INSTALLATION

The cooktop can be installed proud, allowing quick and easy retro-fit installation. A flush-mount installation provides a sleek appearance that blends seamlessly with countertops.

#### LCD TOUCH CONTROL

7-inch color LCD touch control allows for easy interface and use. The seamlessly integrated display is also easy to clean.

#### WI-FI ENABLED FOR SMART CONTROL

The innovative Wi-Fi feature, powered by ThinQ® Technology, brings modern convenience to the kitchen. Monitor the on/off status of the cooktop elements from a mobile device using the ThinQ® app. When combined with a Signature Kitchen Suite Hood, ThinQ® Technology lets the cooktop and hood communicate with each other so the elements and fans are synchronized.

#### Innovation

Wi-Fi Enabled for ThinQ® Monitoring with iPhone / Android App	Yes
Remote Monitoring	Yes
Combine Flex Cooking Zones Into One Large Zone	Yes

#### Cooktop Features

Frameless Design	Yes
Cooktop Surface	Clear Glass, Black Print
Number of Elements	4
Control Type	Touch Controls
Display	7" TFT LCD
Control Lock	Yes
Hot Surface Indicator	Yes
Element Size (inches)	
Front (Left)	8 1/2 x 7 1/8
Front (Right)	6 1/2
Rear (Left)	8 1/2 x 7 1/8
Flex Zone	8 1/2 x 14 3/16
Dual Zone Center	11 1/8
Pan Sensor	Yes

#### Cooktop Performance

Left (Front & Rear) / Boost	3,026 W (208V) / 3,700 W (240V)
Right (Front) / Boost	1,472 W (208V) / 1,800 W (240V)
Flex Zone (Front & Rear) / Boost	3,026 W (208V) / 3,700 W (240V)
Dual Zone Center / Boost	3,026 W (7") 4,662 W (11") : 208V / 3,700 W (7") 5,700 W (11") : 240V

**SKSIT3001GE**  
**30-INCH**  
**FLEX INDUCTION COOKTOP**

**Technical Specs**

ENERGY STAR® Certified	Yes
Energy Source	Electric
Watts	9,400W / 7,688W (240 / 208V)
Required Power Supply	240 / 208V, 60 Hz, 40 Amp
Plug Type	No Plug
Conduit	64 1/8" Flexible 3-Wire

**Dimensions and Weight**

Overall Width (inches)	30 11/16
Overall Height (inches)	4 1/8
Overall Depth (inches)	21 1/16
Net Weight (approx.)	36 lbs.
Shipping Weight (approx.)	42 lbs.

**Warranty Summary\***

Limited Warranty, Parts & Labor	3 Years
---------------------------------	---------

\*These warranties give you specific legal rights and you may have other rights that vary from state to state. For complete warranty details, refer to your Use & Care manual.

# SKSIT3001GE 30-INCH FLEX INDUCTION COOKTOP

## STANDARD INSTALLATION

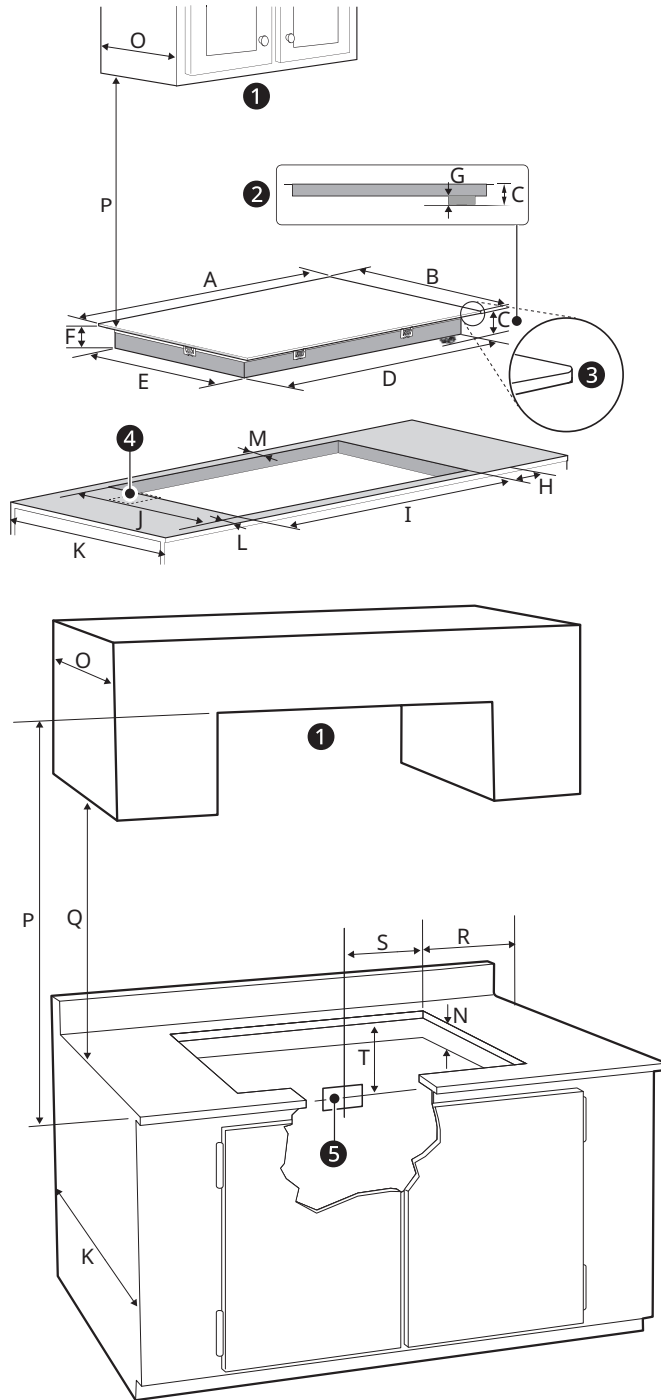

- 1 Do not obstruct these areas.
- 2 Right side
- 3 Radius: 3/8" (10 mm)
- 4 4" x 8" (102 mm x 203 mm) opening to route armored cable if panel is present.
- 5 Approximate location of junction box

-	Dimension/Clearance	30" Cooktop
A	Width of upper plate	30 11/16" (781 mm)
B	Depth of upper plate	21 1/16" (534 mm)
C	Distance from bottom of upper plate to bottom of terminal block enclosure	3 15/16" (101 mm)
D	Width of cooktop base	27 15/16" (710 mm)
E	Depth of cooktop base	18 13/16" (477 mm)
F	Distance from bottom of upper plate to bottom of cooktop base	2 1/2" (64 mm)
G	Height of terminal block enclosure	1 7/16" (37 mm)
H	Distance from side edge of cutout to side of counter	≥ 1 1/8" (28 mm)
I	Width of cutout	≥ 28 1/2" (724 mm) ≤ 28 5/8" (727 mm)
J	Depth of cutout	≥ 19 5/8" (498 mm) ≤ 19 11/16" (501 mm)
K	Depth of bottom cabinets	23 13/16" (605 mm)
L	Distance from front of counter to front edge of cutout	≥ 2 3/16" (55 mm)
M	Distance from rear edge of cutout to nearest combustible surface	≥ 2 1/16" (52 mm)
N	Height below cutout (Empty space is needed underneath the cooktop for optimum performance.)	≥ 5 3/4" (146 mm)
O	Depth of overhead cabinets	≤ 13" (330 mm)
P	Clearance from top of cooking surface to bottom of overhead cabinets	≥ 30" (762 mm)
Q	Clearance from countertop to bottom of adjacent cabinets	≥ 18" (457 mm)
R	Distance from edge of cooktop to nearest combustible wall (either side of unit)	≥ 2" (50 mm)
S	Junction box (approximate location)	10" (254 mm)
T	Junction box (approximate location)	≥ 12" (305 mm)

# SKSIT3001GE 30-INCH FLEX INDUCTION COOKTOP

## FLUSH INSTALLATION

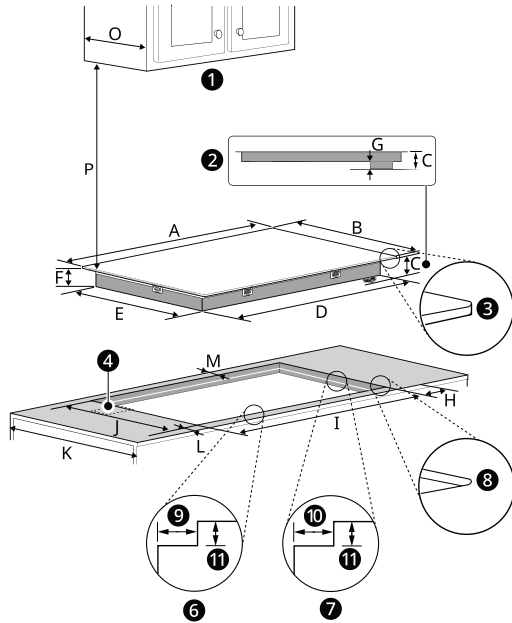

- 1 Do not obstruct these areas.
- 2 Right side
- 3 Radius: 3/8" (10 mm)
- 4 4" x 8" (102 mm x 203 mm) opening to route armored cable if panel is present.
- 5 Approximate location of junction box
- 6 Front and Back Side
- 7 Right and Left Side
- 8 Radius: 1/2" (13 mm)
- 9 3/4" (19 mm)
- 10 1 1/4" (32 mm)
- 11 1/4" (7 mm)

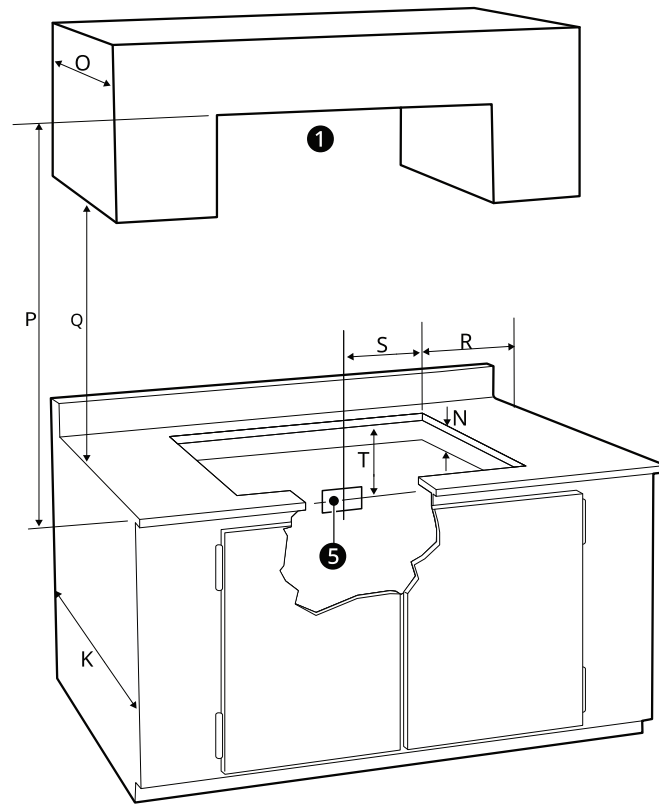

-	Dimension/Clearance	30" Cooktop
A	Width of upper plate	30 11/16" (781 mm)
B	Depth of upper plate	21 1/16" (534 mm)
C	Distance from bottom of upper plate to bottom of terminal block enclosure	3 15/16" (101 mm)
D	Width of cooktop base	27 15/16" (710 mm)
E	Depth of cooktop base	18 13/16" (477 mm)
F	Distance from bottom of upper plate to bottom of cooktop base	2 1/2" (64 mm)
G	Height of terminal block enclosure	1 7/16" (37 mm)
H	Distance from side edge of cutout to side of counter	≥ 1 1/8" (28 mm)
I	Width of cutout	≥ 31" (787 mm) ≤ 31 1/16" (789 mm)
J	Depth of cutout	≥ 21 1/4" (540 mm) ≤ 21 3/4" (542 mm)
K	Depth of bottom cabinets	23 13/16" (605 mm)
L	Distance from front of counter to front edge of cutout	≥ 1 7/16" (36 mm)
M	Distance from rear edge of cutout to nearest combustible surface	≥ 1 5/16" (33 mm)
N	Height below cutout (Empty space is needed underneath the cooktop for optimum performance.)	≥ 6 1/6" (153 mm)
O	Depth of overhead cabinets	≤ 13" (330 mm)
P	Clearance from top of cooking surface to bottom of overhead cabinets	≥ 30" (762 mm)
Q	Clearance from countertop to bottom of adjacent cabinets	≥ 18" (457 mm)
R	Distance from edge of cooktop to nearest combustible wall (either side of unit)	≥ 2" (50 mm)
S	Junction box (approximate location)	10" (254 mm)
T	Junction box (approximate location)	≥ 12" (305 mm)

# SKSIT3001GE 30-INCH FLEX INDUCTION COOKTOP

## FLUSH INSTALLATION – CLEAT OPTION

For this installation, the countertop cut-out will be the same size as the outer edge of the cooktop glass. Attach L-shaped support cleats a to the perimeter of the countertop cut-out. The top edge of the cleat will be attached 1/4" (7 mm) below the surface of the countertop.

Refer to the illustration below. Attach the cleats to the countertop. Consult a countertop supplier for proper methods of attachment.

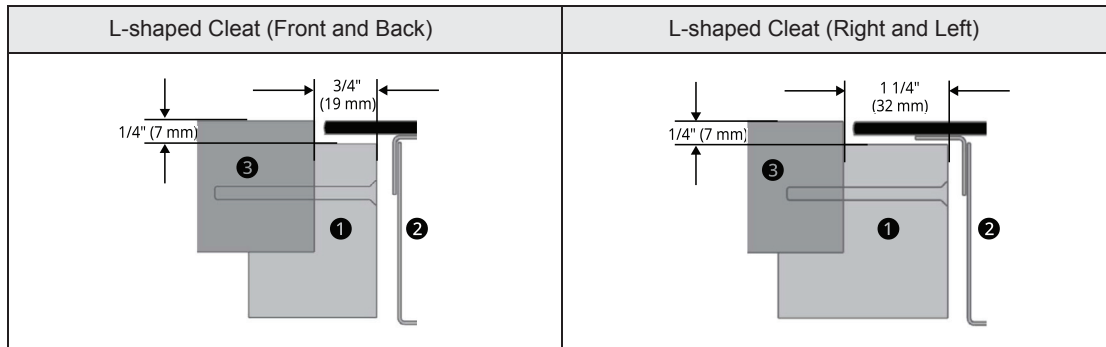
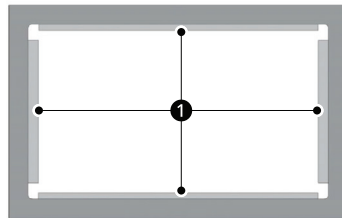

- ① L-Shaped Support Cleat
- ② Cooktop
- ③ Counter Top

### Notes

All electric cooktops run off a single phase, three-wire or four-wire cable, 240/208 volt, 60 hertz, AC-only electrical supply with ground.

Minimum distance between cooktop and overhead cabinetry is 30" (762 mm) for a 30" cooktop.

Make sure the cabinets and wall coverings around the cooktop can withstand the temperatures (up to 93°C [200 °F]) generated by the cooktop.

Allow 2" (50 mm) below the armored cable opening to clear the electric cable and allow space for installation of the junction box on the wall at the back of the cooktop.

Thickness of glass: 3/16" (4 mm)

## RECOMMENDED SPACING BETWEEN COOKTOP AND DRAWER

**CAUTION:** It is very important to keep 3 5/16" (85 mm) distance between the cooktop and a drawer or oven underneath it. ①

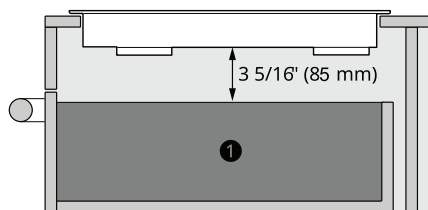

**Standard**

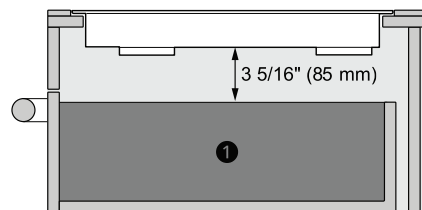

**Flush**