

# SKSCF3001P

## 30-INCH INTEGRATED COLUMN FREEZER



### LARGEST CAPACITY COLUMN

Designed to provide the largest capacity in the industry\*, the 30-inch Integrated Column Freezer features 17.8 cu. ft. of storage capacity.

### SIGNATURE FIT™ INTEGRATED DESIGN

Every integrated column features an intelligent, symmetrical design that allows for flush installation, along with easy door reversal.

### BRILLIANT INTERIOR

The glass and metal interior is not only beautiful, it is designed to help the freezer stay at the set temperature by holding and transferring cold fast and efficiently.

### DISTINCTIVE ICE

The frustum ice shape gives an air of distinction while the removable clear bin holds up to 5.5 lbs., perfect for entertaining.

### ECO FRIENDLY

Engineered to reduce environmental impact and ENERGY STAR® certified.

### Style

Door Style	Panel Ready**
Interior Cabinet Finish	Metal

### Innovation

Wi-Fi Enabled for ThinQ® Control with iPhone / Android App	Yes
Remote Operations	Yes
Smart Inverter Compressor	Yes

### Performance

Ice Plus	Yes
Adaptive Defrost	Yes

### Modes

Sabbath, Ice Plus, Demo, Icemaker On / Off, Power On / Off, Temp Control, Water Filter Reset, Smart Diagnosis, Wi-Fi, Smart Grid

Water Filter (6 Months)	Yes
-------------------------	-----

### Capacity and Storage

Total Capacity (cu. ft.)	17.8
Storage Shelves	3 Adjustable w/LED Lighting, 1 Fixed
Lift and Go™ Ice Drawer	1 Soft Close / Self Close
Lift and Go™ Storage Drawers	3 Soft Close / Self Close
Aluminum Framed Lift and Go™ Door Bins with Removable Inserts	4 Adjustable
Removable Ice Bucket Storage Volume	5.5 lbs.

\*Based on survey of comparable products performed March 1, 2020.

\*\*Shown with professional stainless steel panel and handle accessory kit.

© 2024 Signature Kitchen Suite. All rights reserved. Design, features and specifications are subject to change without notice. Specifications are for planning purposes only. Consult the product's installation instructions for final dimensional data and other details prior to making cutouts or custom panels. Consult with a heating and ventilation engineer for your specific ventilation requirements. Non-metric weights and measurements are approximate. Smart features require Internet access.

1-855-790-6655 | [www.signaturekitchensuite.com](http://www.signaturekitchensuite.com)

**SKSCF3001P**  
**30-INCH INTEGRATED COLUMN FREEZER**

**General Features**

Digital Controls w/White LED Display	Yes
Water Filter Indicator	Yes
Ice Production (24 Hrs.) Cubed	3.5 lbs. (3.8 lbs. with Ice Plus)
Ice On / Off	Yes
Hidden LED Interior Lighting	Yes
Operating Temperatures	-6° to 8° F
Maximum Sound Level (dBA)	39 dBA
Star-K Certified Sabbath Mode	Yes
ENERGY STAR® Certified	Yes

**Installation Features**

Reversible Door	Yes
Four Point Front Adjustable with 8 Wheels	Yes
Attachment Method to Cabinetry	Top with No Visible Screws
Front Serviceable	Yes
Anti-tip Bracket Included	Yes
Joining Kit for Dual Column Installation Included (SKSFJ800P)	Yes

**Technical Specs**

Required Power Supply	115 V, 60 Hz, 15 Amp
Plug Type	3-Prong
Power Cord Length	86 1/2"

**Dimensions and Weight**

Overall Width (inches)	29 3/4"
Overall Height (inches)	83 1/2" Min. – 84 1/2" Max.
Overall Depth Without Panel or Handles (inches)	23 7/8"
Net Weight (approx.)	403 lbs.
Shipping Weight (approx.)	457 lbs.

**Optional Accessories**

Replacement Water Filter	LT1000P-S
Refer to last page for additional accessories	

**Warranty Summary\***

Limited Warranty, Parts & Labor	3 Years
Limited Warranty, Sealed System and Compressor, Parts & Labor	5 Years
Limited Warranty Compressor, Parts Only	10 Years

\*These warranties give you specific legal rights and you may have other rights that vary from state to state. For complete warranty details, refer to your Use & Care manual.

# SKSCF3001P

## 30-INCH INTEGRATED COLUMN FREEZER

### CUTOUT DIMENSIONS – FLUSH INSTALLATION

#### SINGLE COLUMN

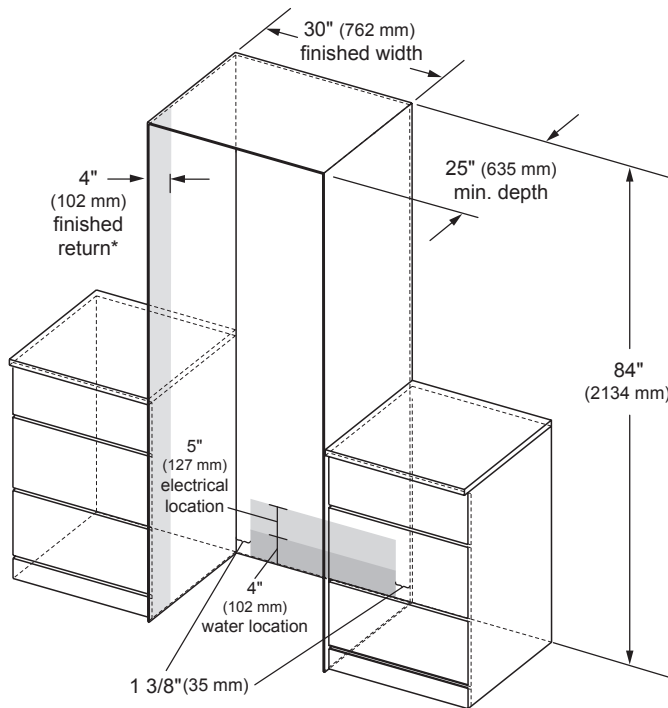

\* A minimum 4" (102 mm) finished return that matches the cabinet exterior is recommended on all sides and the top of the cutout opening. The shaded area will be visible after installation.

#### Notes

Freezer can be installed flush with 3/4" custom panel or optional stainless steel panel kit.

With a 25" (635 mm) cutout depth, the front face of the freezer fits flush with 25" (635 mm) depth adjacent cabinets.

#### Electrical

A 115V, 60Hz., 15 amp power supply is required. An individual properly grounded branch circuit or circuit breaker is recommended. Install a properly grounded 3-prong electrical receptacle recessed into the back wall. Electrical must be located on rear wall as shown.

**Note:** GFI (ground fault interrupter) is not recommended.

#### Water Line

A cold water supply is required for automatic icemaker operation. Water pressure must be between 20 and 120 p.s.i.

Tubing should be long enough to extend to the front of the freezer. Allow enough tubing to accommodate a bend leading into the water line connection.

Water line can enter an opening through floor or back wall.

Install a shut-off valve between the icemaker water valve and cold water supply in the home.

### INSTALLATION CLEARANCES – FLUSH INSTALLATION

#### TOP VIEW

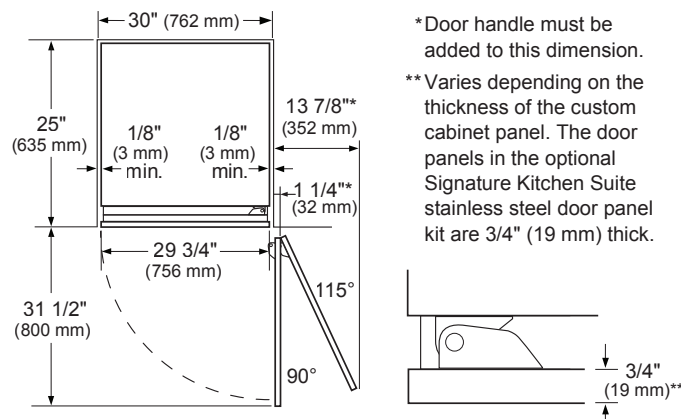

\* Door handle must be added to this dimension.

\*\*Varies depending on the thickness of the custom cabinet panel. The door panels in the optional Signature Kitchen Suite stainless steel door panel kit are 3/4" (19 mm) thick.

#### Notes

**Door Swing Clearances** – The installation must allow for clearances to adjacent walls or cabinets. This freezer is equipped with a 2-position door stop. The factory-set 115° door swing can be adjusted to 90° if clearance to adjacent cabinets or walls is restricted.

**Door Handle Clearances** – The Door Handle depth must be added to the dimension noted to determine the total clearances required from adjacent cabinets or walls. This clearance will vary depending on the custom handle used. When using the Stainless Steel Door Panel Kit w/Handle or the Brushed Aluminum Handle (optional accessories), the door handle clearance with door open 115° is 16" (406 mm).

**SKSCF3001P**  
**30-INCH INTEGRATED COLUMN FREEZER**

**OVERALL PRODUCT DIMENSIONS**

**FRONT VIEW**

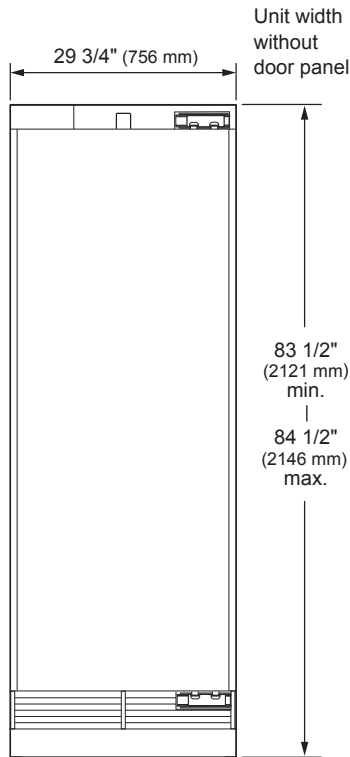

**SIDE VIEW**

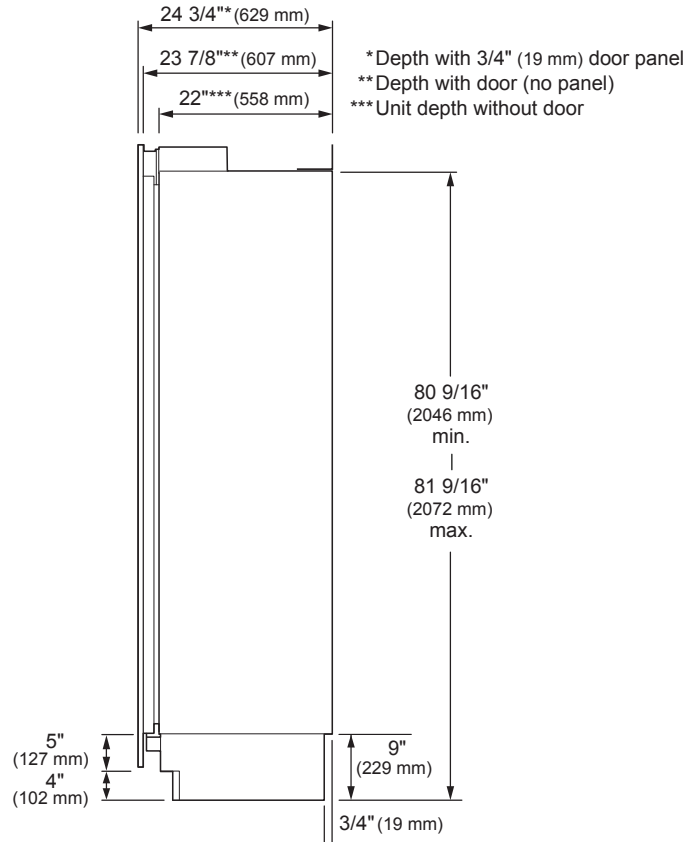

**TOP VIEW**

**DOOR OPEN 90°**

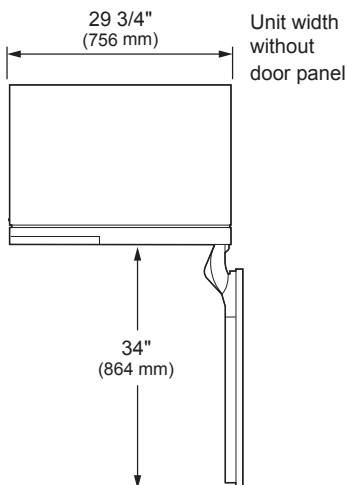

**DOOR OPEN 115°**

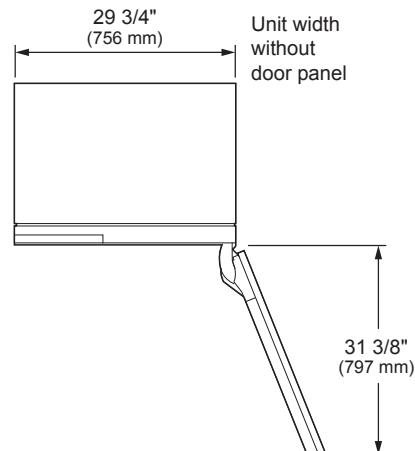

# SKSCF3001P

## 30-INCH INTEGRATED COLUMN FREEZER

### CUSTOM PANEL DIMENSIONS

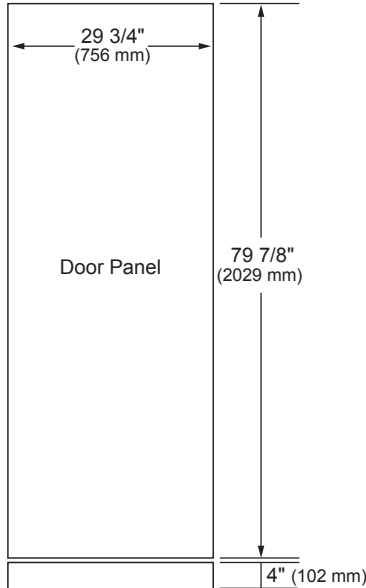

#### Notes

These units are designed to be customized with decorative panels. Field-installed custom door panels or an optional Stainless Steel Panel Kit is required.

**For Custom Panels:** Use templates provided with units to pre-drill holes for mounting panel brackets (provided with unit). Adjustment screws and instructions also provided with units.

Maximum Total Door Panel Weights:  
 30-Inch Integrated Column – 64 lbs.  
 24-Inch Integrated Column – 53 lbs.  
 18-Inch Integrated Column – 44 lbs

#### Design Tips

4" (102 mm) will be visible on the interior sides of the furniture return. It is recommended that both sides of each cutout panel be finished to match the cabinet exterior.

If using custom panels, a custom toe kick is required. The bottom of case is unfinished.

**Door Handles:** Handles are not included with the units. Custom handles are required for installation. Brushed Aluminum Handles are available as an optional accessory.

### OPTIONAL ACCESSORIES

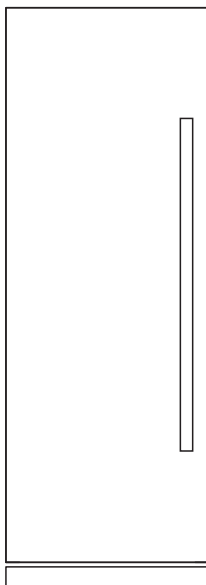

	Professional	Transitional
Stainless Steel Panel / Handle / Toekick Kit	SKSPK305CS	SKSPK305CMT
Retrofit Frame Kit	SKSFK800CS	
Brushed Aluminum Handle		
Medium – 31 11/16"	SKSHK310HS	SKSHK310HST
Long – 48" (For Columns)	SKSHK480HS	SKSHK480HST

#### Included Accessories

Joining Kit for Dual Column Installation (SKSFJ800P)

Refer to the Integrated and Built-in Refrigeration Planning / Installation Guide for details on installing multiple columns, door swing dimensions, cabinet planning, retrofit installation and more.