



OWNER'S MANUAL
ELECTRIC CONVECTION BUILT-IN OVEN

SKSCV3002S



MFL51224534_13

www.signaturekitchensuite.com

Copyright © 2020 - 2025 Signature Kitchen Suite. All Rights Reserved.

TABLE OF CONTENTS

3 IMPORTANT SAFETY INSTRUCTIONS

12 PRODUCT OVERVIEW

- 12 Parts
- 13 Accessories

14 OPERATION

- 14 Control Panel Overview
- 15 Getting Started
- 15 Changing Oven Settings
 - 15 Settings
 - 15 Microwave Quick Start
 - 16 Lockout
 - 16 Date & Time
 - 16 Clock Themes
 - 16 Sabbath Mode
 - 17 Wi-Fi
 - 17 Remote Start
 - 17 Brightness
 - 17 Display
 - 17 Convection Auto Conversion
 - 18 Language Selection
 - 18 Volume
 - 18 Preheat Alarm Light
 - 18 Temperature Adjustment
 - 18 Temperature Units
 - 19 Smart Diagnosis™
 - 19 Program Update
 - 19 Demo Mode
 - 19 Factory Data Reset
 - 19 Open Source License
 - 19 Oven Cooling
 - 20 Timer
- 21 Using the Upper Oven
 - 21 Before Using the Upper Oven
 - 21 Upper Oven Light
 - 21 Microwave Cookware Guide
 - 22 Microwave Cooking Tips
 - 23 Microwave Power Levels
 - 24 +30 seconds
 - 24 Defrost
 - 26 Sensor Operation
 - 27 Using Sensor Cook
 - 28 Convection Bake
 - 28 Broil
 - 29 Speed Cook
 - 29 Auto Cook
 - 33 Soften
 - 34 Melt
 - 35 Warm
 - 35 Proof
 - 35 Popcorn

- 36 Using the Lower Oven
 - 36 Before Using the Oven
 - 36 Lower Oven Light
 - 36 Using Heavy Duty Oven Racks
 - 37 Rack and Pan Placement
 - 37 Oven Vent
 - 37 Using Gliding Oven Racks
 - 38 Bake
 - 39 Convection Modes
 - 40 RapidHeat Roast+
 - 41 Broil
 - 42 Recommended Broiling Guide
 - 44 Warm
 - 45 Proof
 - 45 Probe
 - 48 My Recipes
 - 48 Auto Cook
 - 49 Auto Cook Guide
 - 51 Steam Function
 - 52 Gourmet Steam Guide
 - 53 Sous Vide

54 SMART FUNCTIONS

- 54 LG ThinQ Application
- 56 Smart Diagnosis™ Feature
- 57 FCC Statement
- 57 FCC RF Radiation Exposure Statement

58 MAINTENANCE

- 58 Caring for the Upper Oven
 - 58 Cleaning the Interior
 - 58 Cleaning the Exterior
- 59 Caring for the Lower Oven
 - 59 Self Clean
 - 61 Steam Feeder Tank
 - 61 Cleaning Scale on Oven Bottom
 - 61 Descaling
 - 61 Drying
 - 61 Evaporation
 - 62 SpeedClean™
 - 64 Cleaning the Exterior
 - 66 Changing the Oven Light
 - 66 Removing and Replacing the Oven Door
 - 67 Door Care Instructions

68 TROUBLESHOOTING

- 68 FAQs
- 71 Before Calling for Service

75 WARRANTY

IMPORTANT SAFETY INSTRUCTIONS

Read and follow all instructions when using the oven to prevent the risk of fire, electric shock, personal injury, or damage. This guide does not cover all possible conditions that may occur. Always contact your service agent or manufacturer about problems that you do not understand.

Download this owner's manual at: www.signaturekitchensuite.com

 This is the safety alert symbol. This symbol alerts you to potential hazards that can result in property damage and/or serious bodily harm or death. All safety messages will follow the safety alert symbol and either the word WARNING or CAUTION. These words mean:

 **WARNING** - Indicates a hazardous situation which, if not avoided, could result in death or serious injury.

 **CAUTION** - Indicates a hazardous situation which, if not avoided, could result in minor or moderate injury.

IMPORTANT SAFETY INSTRUCTIONS (UPPER OVEN)

When using electrical appliances basic safety precautions should be followed, including the following:

WARNING

- To reduce the risk of burns, electric shock, fire, injury to persons or exposure to excessive microwave energy when using the upper oven, follow basic safety precautions, including the following.
- **Read all the instructions before using the oven.**
- **As with any appliance, close supervision is necessary when used by children.**
- Read and follow the specific **PRECAUTIONS TO AVOID POSSIBLE EXPOSURE TO EXCESSIVE MICROWAVE ENERGY** on page 7.
- Use this appliance only for its intended purpose, as described in the manual.
Do not use corrosive chemicals or vapors, such as sulfide and chloride, in this appliance. This type of oven is specifically designed to heat, cook, or dry food. It is not designed for industrial or laboratory use.
- **Do not store** this appliance outdoors. Do not use this product near water - for example, near a kitchen sink, in a wet basement, near a swimming pool, or similar location.
- **Do not use this oven for commercial purposes.** It is made for household use only.
- **When cleaning surfaces of door and oven that come together on closing the door, use only mild, nonabrasive soaps, or detergents applied with a sponge or soft cloth.**
- **DO NOT TOUCH HEATING ELEMENTS OR INTERIOR SURFACES OF MICROWAVE OVEN.**
During and after use or cleaning the Interior, do not touch other flammable materials contact heating elements or interior surfaces of microwave oven until they have had sufficient time to cool. Other surfaces, such as windows of microwave oven door, oven lamp, also get hot and may cause burns if not allowed to cool.
- **If your oven is dropped or damaged,** have it thoroughly checked by a qualified service technician before using it.
- **To reduce the risk of fire in the oven cavity:**
 - **Do not overcook food.** Carefully attend to the upper oven when paper, plastic or other combustible materials are placed inside the oven to facilitate cooking.
 - **Do not use the cavity for storage purposes.**
Do not leave paper products, cooking utensils or food in the cavity when not in use.
 - Remove wire twist-ties from paper or plastic bags before placing bags in oven.
- **If materials inside the oven ignite:**
 - **Keep oven door closed**
 - **Turn the oven off**
 - **Disconnect the power cord or shut off power at the fuse or circuit breaker panel.**
- **To avoid electric shock:**
 - **This appliance must be grounded.** Connect only to a properly grounded outlet. See the Installation Guide.
 - **Do not operate this appliance if it has a damaged cord or plug,** if it is not working properly or if it has been damaged or dropped.
 - **Do not immerse the electrical cord or plug in water.**
 - **Keep cord away from heated surfaces.**
 - **Do not let cord hang over edge of table or counter.**
- **Take care when the door is opened to avoid injury.**
- **To avoid improperly cooking some foods:**
 - **Do not heat any type of baby bottle or baby food.** Uneven heating may occur and possibly cause personal injury.
 - **Do not heat small-necked containers,** such as syrup bottles.
 - **Do not deep-fat fry in the upper oven.**
 - **Do not attempt home canning in the upper oven.**
 - **Some products such as whole eggs and sealed containers – for example, closed glass jars – are able to explode and should not be heated in this oven.**

 **WARNING**

- Do not cover or block any openings on the appliance.
- Do not run the oven while it is empty.
- Install or locate this appliance only in accordance with the provided installation instructions.
- This appliance should be serviced only by qualified service personnel. Contact the nearest authorized service facility for examination, repair, or adjustment.
- Liquids, such as water, coffee, or tea can be overheated beyond the boiling point without appearing to be boiling due to surface tension of the liquid. Visible bubbling or boiling when the container is removed from the upper oven is not always present.

THIS COULD RESULT IN VERY HOT LIQUIDS SUDDENLY BOILING OVER WHEN THE CONTAINER IS DISTURBED OR A SPOON OR OTHER UTENSIL IS INSERTED INTO THE LIQUID.

- To reduce the risk of injury to persons;
 - Do not overheat the liquid.
 - Stir the liquid both before and halfway through heating it.
 - Do not use straight-sided containers with narrow necks.
 - After heating, allow the container to stand in the upper oven for a short time before removing the container.
 - Use extreme care when inserting a spoon or other utensil into the container.
- Do not use the oven for the purpose of dehumidification (for example, operating the upper oven with wet newspapers, clothes, toys, electric devices, plants, soil, pets or any other living matter inside it). The oven must only be used for heating or cooking food.
 - The results of misuse can include safety risks such as fire, burns, or death due to electric shock.
- This appliance is not intended for use by persons (Including children) with reduced physical, sensory or mental capabilities, or lack of experience and knowledge, unless they have been given supervision or instruction concerning use of the appliance by a person responsible for their safety. Children should be supervised to ensure that they do not play with the appliance.
 - Improper use may cause damage such as a fire, electric shock or burn.
- Accessible parts may become hot during use. Young children should be kept away to keep them from touching hot surfaces and being burned.
- Children must not be allowed to play with accessories or hang down from the door or any part of the oven.
 - Doing so can cause serious injury and damage.
- If the door or door seals are damaged, the oven must not be operated until it has been repaired by a competent person.
- The appliance and its accessible parts become hot during use. Care should be taken to avoid touching heating elements. Children shall be kept away unless continuously supervised.
- Do not use recycled paper products.
 - They may contain impurities which may cause sparks and/or fires when used in cooking.
- Do not rinse trays and racks by placing them in water just after cooking. This may cause breakage or damage.
 - Improper use could result in damage to the oven.



WARNING

- The oven should be cleaned regularly and any food deposits should be removed.
 - Failure to maintain the oven in a clean condition could lead to deterioration of the surface that could adversely affect the life of the appliance and possibly result in a hazardous situation.
- The door or the outer surface may get hot when the appliance is operating.
- Liquids heated in certain shaped containers (especially cylindrical-shaped containers) may become overheated. The liquid may splash out with a loud noise during or after heating or when adding ingredients (instant coffee. etc.), resulting in harm to the oven and possible injury. In all containers, for best results, stir the liquid several times before heating. Always stir liquid several times between reheatings.
- Do not use coverings, containers or cooking bags made of foil, plastic, wax or paper when speed cooking.
- Place food directly on the trays when cooking unless prompted by the oven to do otherwise.
- Not all plastic wrap is suitable for use in the upper oven.
- Make sure to use suitable cookware during microwave cooking.
 - Use microwave-safe plastics only and use them in strict compliance with the cookware manufacturer's recommendations.
 - Do not microwave empty containers.
 - Do not permit children to use plastic cookware without complete supervision.

SAVE THESE INSTRUCTIONS

PRECAUTIONS TO AVOID POSSIBLE EXPOSURE TO EXCESSIVE MICROWAVE ENERGY

- Do not attempt to operate this oven with the door open since open-door operation can result in harmful exposure to microwave energy. It is important not to defeat or tamper with the safety interlocks.
- Do not place any object between the oven front face and the door or allow soil or cleaner residue to accumulate on sealing surfaces.
- Do not operate the oven if it is damaged.
It is particularly important that the oven door closes properly and that there is no damage to the:
(1) door (bent),
(2) hinges and latches (broken or loosened),
(3) door seals and sealing surfaces.
- The oven should not be adjusted or repaired by anyone except properly qualified service personnel.

SAFETY PRECAUTIONS (LOWER OVEN)

- **DO NOT TOUCH HEATING ELEMENTS OR INTERIOR SURFACES OF OVEN.** Heating elements may be hot even though they are dark in color. Interior surfaces of an oven become hot enough to cause burns. During and after use, do not touch or let clothing or other flammable materials contact heating elements or interior surfaces of oven until they have had sufficient time to cool. Other surfaces, such as oven vent openings and surfaces near these openings, oven doors, and windows of oven doors, also get hot and may cause burns if not allowed to cool.
- **Use care when opening door.** The hot air and steam that escape can cause burns to hands, face and eyes. Let hot air or steam escape from the oven before removing or replacing food in the oven.
- Be sure your appliance is properly installed and grounded by a qualified technician.
- Do not repair or replace any part of the appliance unless specifically recommended in the manual. All other servicing should be performed by a qualified technician.
- Do not use harsh etching, abrasive cleaners or sharp metal scrapers to clean the oven door glass since they can scratch the surface. Scratches may cause the glass to shatter.
- Do not leave items such as paper, cookware or food in the oven when not in use.
- Do not use this oven for purposes other than cooking.
- Never use paper products in the convection oven.
- Do not open the door when the oven is operating.
- Use oven gloves when removing the food and accessories after cooking as the oven & accessories will be very hot.
- Scratching, hitting, jarring, or stressing the glass may weaken its structure causing an increased risk of breakage at a later time.



WARNING

If the door glass or oven heating unit of the oven are damaged, discontinue use of the oven and call for service.

- Do not use plastic to cover food. Use foil or oven-safe lids only.
- Do not allow anyone to climb, stand or hang on the oven door. They could damage the oven and even tip it over, causing severe personal injury.
- Do not line the oven walls, racks, bottom, or any other part of the oven with aluminum foil or any other material. Doing so will disrupt heat distribution, produce poor baking results and cause permanent damage to the oven interior. (Aluminum foil will melt onto the interior surface of the oven.)

- Never attempt to dry a pet in the oven.
- **Never use your appliance for warming or heating the room.**
- Always use pot holders or oven mitts when removing food from the oven. Cookware will be hot. **Use only dry pot holders.** Moist or damp pot holders on hot surfaces may result in burns from steam. Do not let the pot holder touch hot heating elements. Do not use a towel or other bulky cloth to remove food.
- **Do not heat unopened food containers.** Pressure in the containers may cause them to burst which may result in injury.
- **Keep Oven Vent Ducts Unobstructed.**
The oven vent could become hot during oven use. Never block this vent and never place plastic or heat-sensitive items on or near the vent.
- **Check the contents of the oven before using the Wi-Fi features.**
- **DO NOT step or sit on the oven door.** Be sure to follow proper installation instructions.

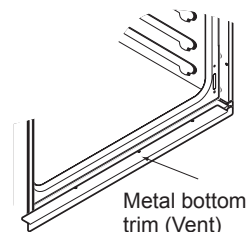
**NOTE**

- For proper oven operation, the vent trim must be installed.

FLAMMABLE MATERIALS**WARNING**

Be certain that all packing materials are removed from the appliance before operating. Keep plastic, clothes, paper, and other flammable materials away from parts of the appliance that may become hot.

- Do not store or use flammable material in the oven. Flammable materials include paper, plastic, pot holders, linens, wall coverings, curtains, and gasoline or other flammable vapors and liquids such as grease or cooking oil. These materials can be ignited when the oven is in use.
- **Wear proper apparel.** Do not wear loose-fitting or hanging garments, which may ignite if they contact hot surfaces, and cause severe burns.
- Do not use the oven for drying clothes. Only use the oven for its intended purpose.
- If a cabinet storage is provided directly above the ovens, only place items in it that are not frequently used and can be safely stored in an area subjected to heat. Temperatures may be unsafe for volatile items such as flammable liquids, cleaners or aerosol sprays.
- Use only oven-safe cookware in the oven. Flammable materials such as paper and plastic can be ignited when the oven is in use.

ELECTRICAL SAFETY**CAUTION**

Be certain that all packing materials are removed from the appliance before operating. Keep plastic, clothes, paper, and other flammable materials away from parts of the appliance that may become hot.

- Always disconnect power from the appliance before servicing.
- Do not use aluminum foil or any other material to line the oven bottom.
Improper installation of oven liners may result in a risk of electric shock or fire.
- Do not allow aluminum foil or the temperature probe to contact heating elements.

WARNING

Before replacing the oven light bulb, switch off the electrical power to the oven at the main fuse or circuit breaker panel. Failure to do so can result in severe personal injury, death, or electric shock.

WARNING

- **DO NOT place aluminum foil directly on the oven bottom.**

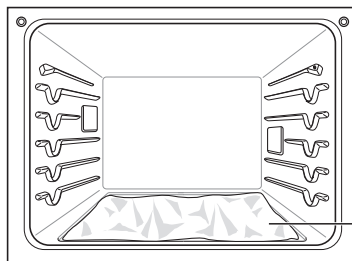

No aluminum foil

CHILD SAFETY

- Do not touch the hot surface between the upper oven door and the lower oven door on the front of the oven while the oven is in operation. The surface becomes hot and can cause burns and other injury.
- Do not leave small children unattended near the oven.

WARNING

Do not leave children alone or unsupervised near the appliance when it is in use or is still hot. Children should never be allowed to sit or stand on any part of the appliance as they could be injured or burned.

- Never let a child hang on the oven door.
- Do not allow children to crawl into the oven.
- Let hot cookware cool in a safe place, out of reach of small children.
- Children should not be allowed to play with controls or other parts of the appliance.

ENERGY SAVING TIPS

- Multiple-rack cooking saves time and energy. Whenever possible, cook foods requiring the same cooking temperature together in one oven.
- For optimal performance and energy savings, follow the guides for proper rack and pan placements.
- Reduce energy use by cleaning light oven soils with the SpeedClean™ feature instead of self-clean.
- Avoid opening the oven door more than necessary during use. This helps the oven maintain temperature, prevents unnecessary heat loss, and saves on energy use.

SAFETY DURING USE

- Do not touch the oven racks while they are hot.
- Always place oven racks in the desired location while the oven is cool. If a rack must be moved while the oven is hot, do not let the pot holder contact the hot heating element in the oven.

- Use caution with the Timed Cook or Delayed Timed Cook features. Use the automatic timer when cooking cured or frozen meats and most fruits and vegetables. Foods that can easily spoil, such as milk, eggs, fish, meat or poultry, should be chilled in the refrigerator first. Even when chilled, they should not stand in the oven for more than 1 hour before cooking begins, and should be removed promptly when cooking is complete. Eating spoiled food can result in sickness from food poisoning.
- Accessible parts may become hot when the grill is in use.
- Do not place food or cookware on the bottom of the oven cavity. Doing so will cause permanent damage to the oven bottom finish.
- **Do not use water on grease fires.** Should an oven fire occur, leave the oven door closed and turn the oven off. If the fire continues, throw baking soda on the fire or use a fire extinguisher. Do not put water or flour on the fire. Flour may be explosive and water can spread a grease fire and cause personal injury.
- Pull the oven rack to the stop-lock position when loading and unloading food from the oven. This helps prevent burns caused by touching hot surfaces of the door and oven walls.
- Do not put your hand under the controller or between the door and metal bottom trim (vent) during operation. The outside of the oven can become very hot to the touch.
- Do not use the oven if a heating element develops a glowing spot during use or shows other signs of damage. A glowing spot indicates the heating element may fail and present a potential burn, fire, or shock hazard. Turn the oven off immediately and have the heating element replaced by a qualified service technician.
- When using cooking or roasting bags in the oven, follow the manufacturer's directions.

SAFETY WHEN CLEANING

- Open a window or turn on a ventilation fan or hood before self-cleaning.
- If the oven is heavily soiled with oil, self-clean the oven before using the oven again. The oil could cause a fire.
- Wipe up heavy soil on the bottom of the oven before using the Self Clean function.
- **Do not use oven cleaners.** Commercial oven cleaner or oven liner protective coating of any kind should not be used in or around any part of the oven.
- Never keep pet birds in the kitchen. The health of birds is extremely sensitive to the fumes released during an oven self-clean cycle. Fumes may be harmful or fatal to birds. Move birds to a well-ventilated room.
- Clean in the self-clean cycle only parts listed in this manual. Before self-cleaning the oven, remove the broiler pan, all oven racks, the meat probe and any cookware or food from the oven.
- Important Instruction. The oven displays an F error code and sounds three long beeps during the self-cleaning process if it malfunctions in the self-clean mode. Switch off the electrical power to the main fuse or breaker and have the oven serviced by a qualified technician.
- Never pour cold water over a hot oven for cleaning. Doing so may cause the oven to malfunction.
- Make sure oven lights are cool before cleaning.
- **Do not clean door gasket.** The door gasket is essential for a good seal. Care should be taken not to rub, damage, or move the gasket.
- If there is a fire in the oven during self-clean, turn the oven off and wait for the fire to go out. Do not force the door open. Introduction of fresh air at self-clean temperatures may lead to a burst of flame from the oven. Failure to follow this instruction may result in severe burns.

- **DO NOT block the oven vent during operation.** This can damage the electric parts of the oven. Air must be able to move freely. The metal bottom trim (vent) should be properly assembled on the front bottom of oven before installing the oven door.

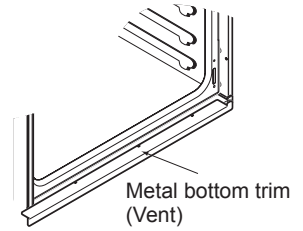

COOK MEAT AND POULTRY THOROUGHLY

- To protect against food-borne illnesses, cook meat and poultry thoroughly. The USDA has indicated the following as safe minimum internal temperatures for consumption:
 - Ground meat: 160 °F
 - Poultry: 165 °F
 - Beef, veal, pork, or lamb: 145 °F
 - Fish/seafood: 145 °F

SAFETY STANDARD FOR BUTTON CELL OR COIN BATTERIES

WARNING

- **INGESTION HAZARD:** This product contains a button cell or coin battery.
- **DEATH** or serious injury can occur if ingested.
- A swallowed button cell or coin battery can cause **Internal Chemical Burns** in as little as **2 hours**.
- **KEEP** new and used batteries **OUT OF REACH of CHILDREN**.
- **Seek immediate medical attention** if a battery is suspected to be swallowed or inserted inside any part of the body.



- Remove and immediately recycle or dispose of used batteries according to local regulations and keep away from children.
 - Do NOT dispose of batteries in household trash or incinerate.
- Even used batteries may cause severe injury or death.
- Call a local poison control center for treatment information.
- Non-rechargeable batteries are not to be recharged.
- Do not force discharge, recharge, disassemble, heat above 140 °F or incinerate.
 - Doing so may result in injury due to venting, leakage or explosion resulting in chemical burns.
- Product contains non-replaceable batteries.
- Battery Type : MS621FE
- Nominal Voltage : 3.0 V

PRODUCT OVERVIEW

Parts

Make sure to understand the name and function of each part.

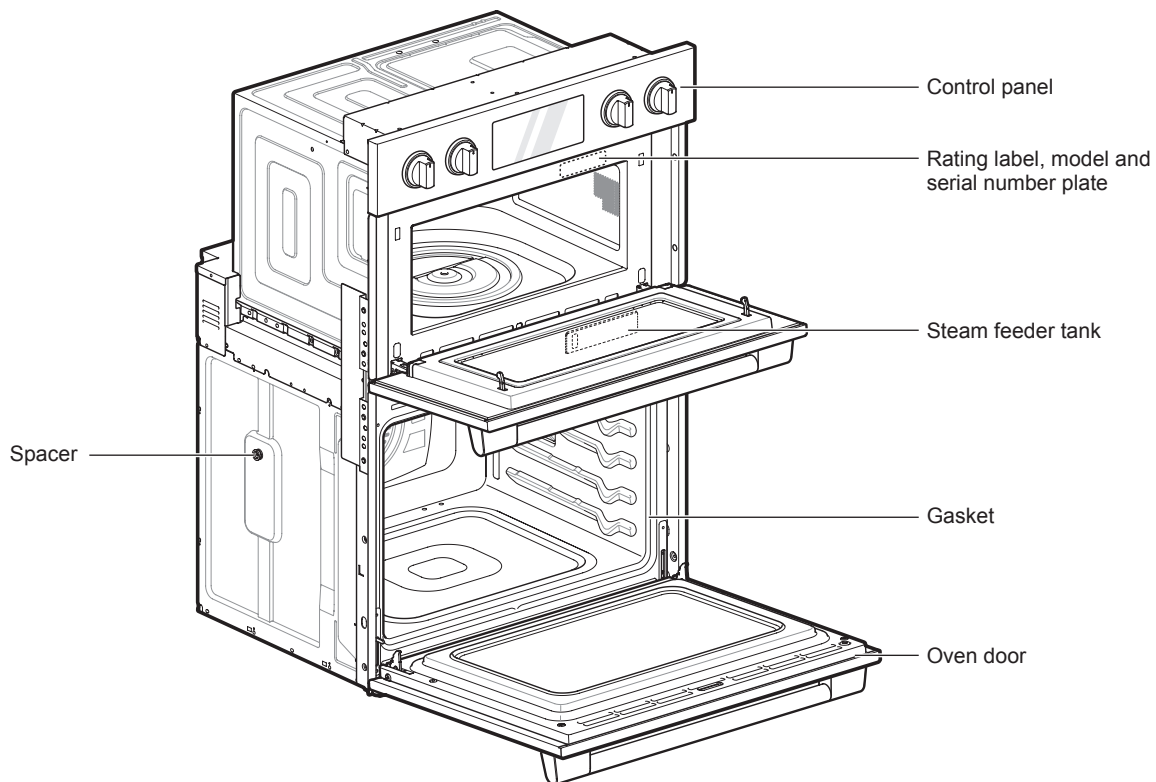

NOTE

- The model and serial number can be verified at the rating label.

Accessories

Make sure that all parts are included after purchasing this product.

Accessories for Upper Oven

The turntable rotates in both directions to help food cook more evenly. Do not operate the microwave oven without the glass tray in place.

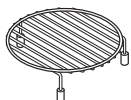

Rack (1 ea)
(For the Convection Bake, Broil and Speed Cook function)



Metal Tray (1 ea)
(For the Convection Bake, Broil and Speed Cook function)



Glass Tray (1 ea)
(For the Microwave and Defrost function)



Shaft (1 ea)



Rotating Ring (1 ea)

Accessories for Lower oven

Accessories for Cooking

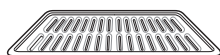

Grid (1 ea)



Heavy duty rack (1 ea)



Broiler pan (1 ea)



Gliding rack (2 ea)



Meat probe (1 ea)

Accessories for Installation



4x14 Wood Screws for Mounting (6 ea)
(4 needed for installation and 2 extras)

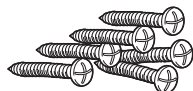

3x27 Wood Screws for Mounting for Flush Installation (6 ea)



4x22 Self-Tapping Screws for Cover Bracket (2 ea)

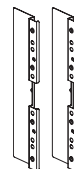

Cover Brackets for Flush Installation (2 ea)



4x10 Screws for Bottom Decorative Trim (2 ea)



Bottom Decorative Trim (1 ea)

Manuals



Owner's manual (1 ea)

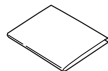

Installation manual (1 ea)

NOTE

- Contact SIGNATURE KITCHEN SUITE Customer Service if any accessories are missing.
- For your safety and for extended product life, only use authorized components.
- The manufacturer is not responsible for product malfunction or accidents caused by the use of separately purchased, unauthorized components.
- The images in this guide may be different from the actual components and accessories, which are subject to change by the manufacturer without prior notice for product improvement purposes.
- **Do not remove gliding racks from the base packing.**

OPERATION

Control Panel Overview

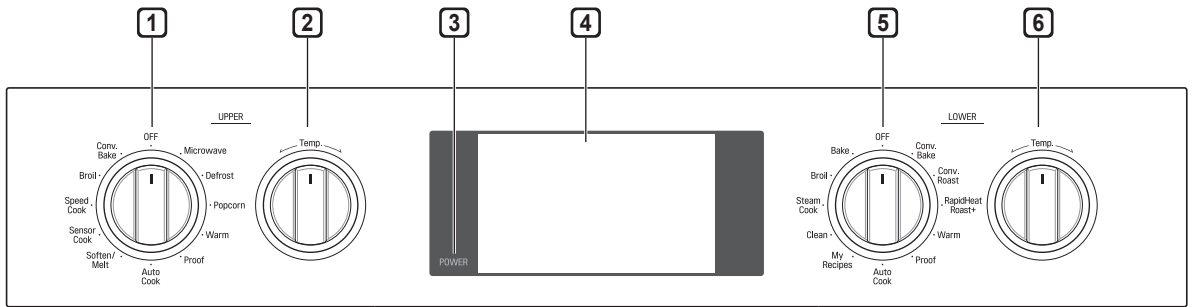

- | | |
|-------------------------------|-----------------------------------|
| 1 Upper Oven Mode Knob | 4 LCD Touchscreen for Oven |
| 2 Upper Temp Knob | 5 Lower Oven Mode Knob |
| 3 LCD Display On/Off | 6 Lower Temp Knob |

Display Icons

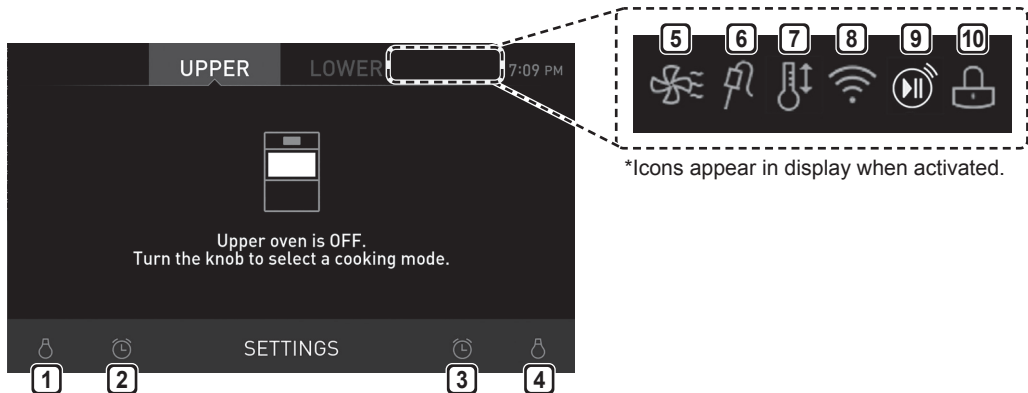

*Icons appear in display when activated.

- | | |
|--|--|
| 1 Lamp Icon (Upper Oven)
Touch to turn light on/off | 7 Auto Conversion Icon
Appears when Convection Auto Conversion is turned on |
| 2 Timer Icon (Upper Oven)
Touch to set a timer | 8 Wi-Fi Icon
• Appears when range is connected to Wi-Fi
• Appears when range is disconnected from Wi-Fi or is not registered |
| 3 Timer Icon (Lower Oven)
Touch to set a timer | 9 Remote Start Icon
Appears when Remote Start is active |
| 4 Lamp Icon (Lower Oven)
Touch to turn light on/off | 10 Lock Icon
Appears when Lockout is on |
| 5 Oven Cooling Icon
Appears during or after oven operation to indicate cooling fan is running in oven | |
| 6 Probe Icon
Appears when probe is connected | |

Getting Started

After turning on the range for the first time, adjust the settings to suit your preferences.

- 1 Touch POWER on the LCD display.

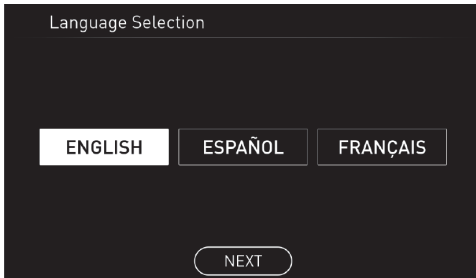

- 2 After the startup animation, select the desired language and touch NEXT.
- 3 Scroll the fields up or down to set the correct date, and touch NEXT.
- 4 Set the correct time of day and choose between a 12-hour or 24-hour time format. Then touch NEXT.
- 5 If desired, change the default clock theme by swiping through the examples. Then press NEXT.
- 6 Read through the application guide in the display and touch DONE.
- 7 Turn the oven mode knob.
- 8 The mode screen appears in the display.

Changing Oven Settings

Settings

To adjust settings after the initial setup, touch the display to open the Main screen. Touch Settings at the bottom center of the Main screen.

Swipe the screen or touch the <> arrow keys to navigate through the Settings screens.

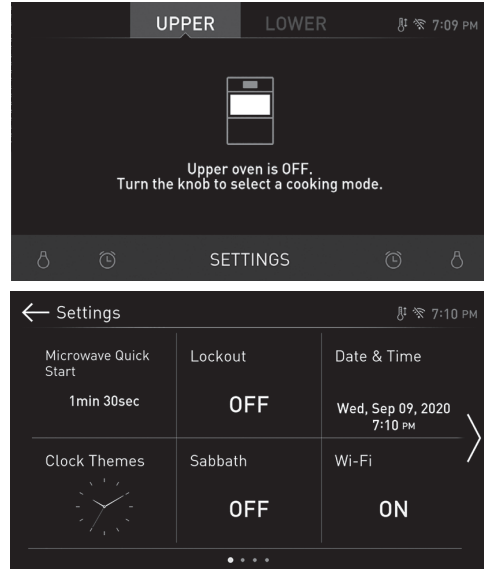

Location of Settings

- Page 1: Microwave Quick Start, Lockout, Date & Time, Clock Themes, Sabbath Mode, Wi-Fi Setup
- Page 2: Remote Start, Brightness, Display, Convection Auto Conversion, Language Selection, Volume
- Page 3: Preheat Alarm Light, Temperature Adjustment, Temperature Units, Smart Diagnosis™, Program Update, Demo Mode
- Page 4: Factory Data Reset, Open Source License

Microwave Quick Start

Use the Microwave Quick Start setting to adjust the preset cook time that is activated when you press Start without setting a time. The preset time can be set from 1 second to 5 minutes.

Setting Cook Time

- 1 Touch Settings at the center bottom of the main screen.
- 2 Touch Microwave Quick Start on the first Settings screen.
- 3 Set the cook time.
- 4 Touch OK.

Lockout

The Lockout feature automatically prevents most oven controls from being turned on. It does not disable the clock, timer and the interior oven light.

Lock

- 1 Touch Settings at the center bottom of the Main screen.
- 2 Touch Lockout on the first Settings screen.
- 3 When Lockout is turned on, the lock icon  appears at the top of the display.

Unlock

- 1 Touch any part of screen while Lockout is on.
- 2 A popup screen appears. Touch Unlock for 3 seconds.
- 3 The lock icon disappears from the top of the display.

Date & Time

The date and time show in the LCD display when the oven is not in use.

Setting Date

- 1 Touch Settings at the center bottom of the Main screen. Then touch Date & Time on the Settings screen.
- 2 Touch Date, and scroll to set the correct date.
- 3 Touch OK.

Setting Time of Day

- 1 Touch Settings at the center bottom of the Main screen. Then touch Date & Time on the Settings screen.
- 2 Touch Time, and scroll to set the correct hour and minutes. You can also touch the number pad icon  and enter the desired numbers.
- 3 Select either a 12-hour or 24-hour clock mode (12H/24H).
- 4 Touch OK.

Clock Themes

There are six different clock themes available, including several analog and digital clocks.

Selecting a Clock Theme

- 1 Touch Settings at the center bottom of the Main screen.
- 2 Touch Clock Themes on the first Settings screen and swipe to browse through the clock themes.
- 3 Select a clock theme and touch OK.

Sabbath Mode

Sabbath mode is used on the Jewish Sabbath and Holidays.

While the oven is in Sabbath mode, the temperature cannot be changed and the timer, light, and alarm functions are disabled. Only the cooking mode and set temperature appear in the display.

NOTE

- If the oven light is turned ON when the Sabbath mode is activated, the oven light will stay ON. If the oven light needs to be OFF, be sure to turn the oven light OFF before activating the SABBATH mode. SABBATH mode can only be used in Bake mode.

Setting Sabbath Mode

- 1 Disconnect the probe. The Probe function is not available in Sabbath mode.
- 2 Touch Settings at the center bottom of the Main screen, and touch Sabbath in the first Settings screen.
- 3 Set the desired temperature and cook time. Any cook time can be set from 1 minute to 73 hours 59 minutes.
- 4 To stop Sabbath mode, press POWER on the LCD display.

NOTE

- If a cook time is set, the oven turns off automatically at the end of the cook time, without chiming. The oven remains in Sabbath mode, but is turned off.
- If no cook time is set, the oven will not automatically turn off.
- After a power failure, the display will turn back on in Sabbath mode, but the oven will be off.
- In Sabbath mode, the upper oven functions are blocked and the Wi-Fi network cannot be connected.

Wi-Fi

Connect the appliance to a home Wi-Fi network to use Remote Start and other smart functions. See the Smart Functions section for more details.

Setting Up Wi-Fi

- 1 Touch Settings at the center bottom of the Main screen, and touch Wi-Fi in the first Settings screen.
- 2 Follow the instructions in the Wi-Fi Guide in the display.
- 3 Select ON, OFF, or RESET and touch OK.
- 4 If the product is connected to Wi-Fi and ON is selected, the Wi-Fi icon  appears at the top of the display.
- 5 Selecting RESET initializes the IP address.

Remote Start

Remotely starts or stops the preheating function of the appliance. The appliance must be registered on a home Wi-Fi network to use Remote Start.

Setting Remote Start

- 1 Touch Settings at the center bottom of the Main screen, and touch Remote Start in the first Settings screen.
- 2 Select On or Off and touch OK.
- 3 If ON is selected, the Remote Start icon  appears at the top of the display.

Brightness

Adjust the brightness of the LCD display from 20 % to 100 % in increments of 20 %.

Setting Display Brightness

- 1 Touch Settings at the center bottom of the Main screen, swipe to the second Settings screen, and touch Brightness.
- 2 Adjust the display brightness by touching and dragging the dot across the bar, by tapping anywhere on the bar, or by touching + or -.
- 3 Touch OK.

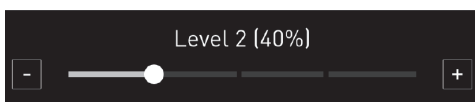

Display

Set the length of time before the display sleeps.

There are three options you can select.

- **ON** : Always on
- **OFF** : Automatically turns off if idle for 30 minutes.
- **Night OFF** : Turns off from 10:00 PM to 5:00 AM.

Setting Display Option

- 1 Touch Settings at the center bottom of the Main screen, swipe to the second Settings screen, and touch Display.
- 2 Select the desired option.
- 3 Touch OK.

Convection Auto Conversion

There is no need to remember to convert standard recipe temperatures for convection cooking. Convection Auto Conversion automatically subtracts 25 °F / 14 °C from the set temperature when a convection cooking mode is selected. The converted temperature appears in the display once preheating is finished.

For example, select Convection Bake and enter 350 °F. The temperature will auto-convert to 325°F and display the converted temperature.

Convection Auto Conversion is turned ON by default.

Turning Convection Auto Conversion On/Off

- 1 Touch Settings at the center bottom of the Main screen, swipe to the second Settings screen, and touch Convection Auto Conversion.
- 2 Select ON or OFF.
- 3 When Convection Auto Conversion is ON, the icon  appears at the top of the display.

NOTE

If Convection Auto Conversion is ON, the icon  flashes in the display while cooking in a convection mode.

Language Selection

Set the display language to English, Spanish, or French.

Selecting a Language

- 1 Touch Settings at the center bottom of the Main screen, swipe to the second Settings screen, and touch Language Selection.
- 2 Select the desired language.
- 3 Touch OK.

Volume

Adjust the volume of the oven controls.

Setting the Volume

- 1 Touch Settings at the center bottom of the Main screen, swipe to the second Settings screen, and touch Volume.
- 2 Select Mute, Low, or High.
- 3 Touch OK.

Preheat Alarm Light

When the oven reaches its set-temperature, the preheating alarm light flashes 5 times or until the oven door is opened.

You can turn the preheat alarm light on or off.

Setting the Preheat Alarm

- 1 Touch Settings at the center bottom of the Main screen, swipe to the second Settings screen, and touch Preheat Alarm Light.
- 2 Select ON or OFF.
- 3 Touch OK.

Temperature Adjustment

Your new oven may cook differently than the one it replaced. Use your new oven for a few weeks to become more familiar with it before changing the temperature settings. If after familiarizing yourself with the new oven, you still think that it is too hot or too cold, you can adjust the oven temperature yourself.

NOTE

To begin, either raise or lower the thermostat 15 °F (8 °C). Try the oven with the new setting. If the oven still needs adjustment, raise or lower the thermostat again, using the first adjustment as a gauge. For example, if the adjustment was too much, raise or lower the thermostat 10 °F (5 °C). If the adjustment was not enough, raise or lower the thermostat 20 °F (12 °C). Proceed in this way until the oven is adjusted to your satisfaction.

Adjusting the Thermostat

- 1 Touch Settings at the center bottom of the Main screen, swipe to the third Settings screen, and touch Temperature Adjustment.
- 2 To make large adjustments, drag the central indicator toward the + or - ends of the scale or tap a location on the scale. To make small adjustments, tap + or - to raise or lower the thermostat in 1-degree increments. Tap and hold + or - to scroll up or down the scale.
- 3 When the desired change appears above the range, touch OK.

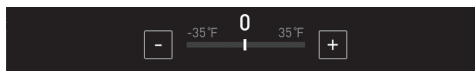

Temperature Units

Set the oven temperature display to show either Fahrenheit or Celsius units.

The oven defaults to Fahrenheit unless changed by the user.

Setting Temperature Units

- 1 Touch Settings at the center bottom of the Main screen, swipe to the third Settings screen, and touch Temperature Units.
- 2 Select °F or °C.
- 3 Touch OK.

Smart Diagnosis™

Smart Diagnosis™ can be run through a smartphone application or by calling for support. Place your smartphone's mouthpiece near the top left corner of the screen. See "Smart Diagnosis Function" in the Smart Functions section for detailed instructions.

- 1 Touch Settings at the center bottom of the Main screen, swipe to the third Settings screen, and touch Smart Diagnosis.
- 2 Touch START to start the diagnostic tone.

Program Update

Once the appliance is connected to a home Wi-Fi network, use this setting to check for available programming updates and install them.

- 1 Touch Settings at the center bottom of the Main screen, swipe to the third Settings screen, and touch Program Update.
- 2 The display shows available programming updates. Touch UPDATE to download and install the new version.

Demo Mode

Demo Mode for showroom use only. The oven will not heat up.

- 1 Touch Settings at the center bottom of the Main screen, and touch Demo Mode on the Settings screen.
- 2 Select either the ON or OFF mode.
- 3 Touch OK.



NOTE

- When Demo Mode is on, the appliance will not heat up.
- The oven Demo Mode icon appears in the display if the Demo Mode is on.

Factory Data Reset

This function returns all settings to the factory defaults.

- 1 Touch Settings at the center bottom of the Main screen, swipe to the third Settings screen, and touch Factory Data Reset.
- 2 If you want to reset data to the factory defaults, touch RESET and then OK.



WARNING

- All stored data will be deleted.

Open Source License

This screen displays a list of the open source software contained in this product. Refer to the indicated licenses for the terms and conditions of their use.

- 1 Touch Settings at the center bottom of the Main screen and swipe to the fourth Settings screen.
- 2 Touch Open Source License.

Oven Cooling

The oven cooling icon appears in the display if the temperature inside the oven is high during or after operation. The icon disappears if the oven temperature is below 210°F (100°C).



Timer

The oven timers don't affect oven operation or cooking time. Use them as extra kitchen timers. Once the time runs out, the oven chimes and "Timer 1 or 2 finished" appears in the display.

Setting the Timer

- 1 Touch either clock icon (🕒) at the bottom of the display.
- 2 Scroll through the numbers in the popup until the desired time appears in the display or touch the number pad icon (🔢) to enter the numbers directly and touch OK.

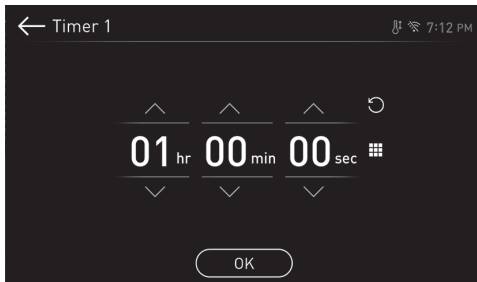

- 3 The time remaining appears next to the clock icon in the display.

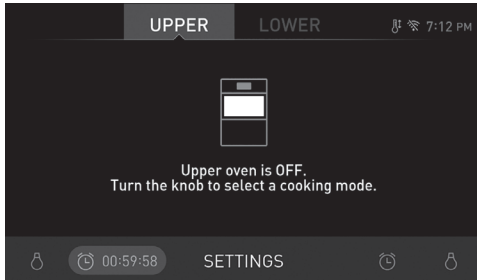

Adjusting or Cancelling the Timer

- 1 Touch the remaining time next to the clock icon in the display.
- 2 To cancel the timer, touch Reset (🔄) in the popup. Then touch OK.
- 3 To adjust the time, scroll the numbers in the popup until the desired time appears. Then touch OK.
- 4 The remaining time in the display is adjusted.

Using the Upper Oven

Before Using the Upper Oven

NOTE

- To avoid risk of personal injury or property damage, do not use stoneware, metal cookware, or metal rimmed cookware in the oven.
- To program the oven, make sure you touch the center of each key firmly since the areas between the keys will not activate the oven. A tone will sound each time a key is touched correctly. Don't touch several keys at once.
- Do not strike the control panel with silverware, cookware, etc. Breakage may occur.
- Always use caution when taking cookware out of the oven. Some dishes absorb heat from the cooked food and may be hot. See Cookware Guide earlier in this section for more information.

NOTE

- Do not rinse containers by placing them in water immediately after cooking. This may cause breakage. Also, always allow the turntable to cool before removing it from the oven.
- Never operate the oven when it is empty. Food or water should always be in the oven during operation to absorb the microwave energy.
- Do not use the oven to dry newspapers or clothes. They may catch fire.
- Use thermometers that have been approved for microwave oven cooking.
- The turntable must always be in place when you operate the oven.
- Do not use your microwave oven to cook eggs in the shell. Pressure can build up inside the shell, causing it to burst.

Upper Oven Light

- 1 Touch **Upper Light** to turn the upper oven light on or off.

Microwave Cookware Guide

Use	Do Not Use
<p>OVENPROOF GLASS (treated for high intensity heat): utility dishes, loaf dishes, pie plates, cake plates, liquid measuring cups, casseroles and bowls without metallic trim.</p> <p>CHINA: bowls, cups, serving plates, and platters without metallic rims.</p> <p>PLASTIC: Plastic wrap (as a cover)- lay the plastic wrap loosely over the dish and press it to the sides. Vent plastic wrap by turning back one edge slightly to allow excess steam to escape. The dish should be deep enough so that the plastic wrap will not touch the food. As the food heats it may melt the plastic wrap wherever the wrap touches the food.</p> <p>Use plastic dishes, cups, semi-rigid freezer containers and plastic bags only for short cooking time. Use these with care because the plastic may soften from the heat of the food.</p> <p>PAPER: Paper towels, waxed paper, paper napkins, and paper plates with no metallic rim or design. Check the manufacturer's label before using in the microwave oven.</p> <p>NOTE: Do not use recycled paper products in the microwave oven. They sometimes contain impurities that cause arcing and sparking.</p>	<p>METAL CONTAINERS: Metal shields the food from microwave energy and produces uneven cooking. Also avoid metal skewers, thermometers, or foil trays. Metal containers can cause arcing, which can damage the microwave oven.</p> <p>METAL DECORATION: Metal-rimmed or metal-banded dinnerware, casserole dishes, etc. The metal rim interferes with normal cooking and may damage the oven.</p> <p>ALUMINUM FOIL: Avoid large sheets of aluminum foil because they hinder cooking and may cause harmful arcing. Use small pieces of foil to shield poultry legs and wings. Keep ALL aluminum foil at least 1 inch from the side walls and door of the oven.</p> <p>WOOD: Wooden bowls and boards will dry out and may split or crack when you use them in the microwave oven. Baskets react in the same way.</p> <p>TIGHTLY COVERED COOKWARE: Be sure to leave openings for steam to escape from covered containers. Pierce plastic pouches of vegetables or other food items before cooking. Tightly closed pouches could explode.</p> <p>BROWN PAPER: Avoid using brown paper bags. They absorb too much heat and could burn.</p> <p>FLAWED OR CHIPPED COOKWARE: Any container that is cracked, flawed, or chipped may break in the oven.</p> <p>METAL TWIST TIES: Remove metal twist ties from plastic or paper bags. They become hot and could cause a fire.</p>

Microwave Cooking Tips

Keeping an Eye on Things

Always watch your food while it cooks. The light inside the upper oven turns on automatically when the oven is cooking so you can monitor the cooking process. Directions given in recipes to elevate, stir, and the like should be thought of as the minimum steps recommended. If the food seems to be cooking unevenly, simply make the necessary adjustments you think appropriate to correct the problem.

Factors Affecting Microwave Cooking Times

Many factors affect cooking times. The temperature of ingredients used in a recipe makes a big difference in cooking times. For example, a cake made with ice-cold butter, milk, and eggs will take considerably longer to bake than one made with ingredients that are at room temperature. Some recipes, particularly those for bread, cake, and custards, recommend that food be removed from the oven when they are slightly undercooked.

This is not a mistake. When allowed to stand, usually covered, these foods will continue to cook outside of the oven as the heat trapped within the outer portions of the food gradually travels inward. If the food is left in the oven until it is cooked all the way through, the outer portions will become overcooked or even burnt. Practice will improve your ability to estimate both cooking and standing times for various foods.

Density of Food

Light, porous food such as cakes and breads cook more quickly than heavy, dense foods such as roasts and casseroles. You must take care when microwaving porous food so that the outer edges do not become dry and brittle.

Height of Food

The upper portion of tall foods, particularly roasts, will cook more quickly than the lower portion.

Therefore, it is wise to turn tall food several times during cooking.

Moisture Content of Food

Because the heat generated from microwaves causes moisture to evaporate, relatively dry food such as roasts and some vegetables should either be sprinkled with water prior to cooking or covered to retain moisture.

Bone and Fat Content of Food

Bones conduct heat and fat cooks more quickly than meat. Care must be taken when cooking bony or fatty cuts of meat in order to prevent unevenly cooked or overcooked meat.

Quantity of Food

The number of microwaves in your oven remains constant regardless of how much food is being cooked. Therefore, the more food you place in the oven, the longer the required cooking time. Remember to decrease cooking times by at least one third when halving a recipe.

Shape of Food

Microwaves penetrate only about 3/4 of an inch (2 cm) into food. The interior portion of thick foods is cooked as the heat generated on the outside travels inward. Only the outer edge of food is cooked by microwave energy; the rest is cooked by conduction. The worst possible shape for a food that is to be microwaved is a thick square.

The corners will burn long before the center is even warm. Round thin foods and ring-shaped foods cook most successfully in the microwave.

Covering

A cover traps heat and steam which causes food to cook more quickly. Use a lid or microwave cling film with a corner folded back to prevent splitting.

Covering with Parchment Paper

Parchment paper (not waxed paper) is microwave safe. Because it makes a looser cover than a lid or clingfilm, greaseproof paper allows the food to dry out slightly.

Stirring

Stirring is one of the most important of all microwaving techniques. In conventional cooking, food is stirred for the purpose of blending. Microwaved food, however, is stirred in order to spread and redistribute heat. Always stir from the outside towards the centre as the outside of the food heats first.

Placing Thicker Portions Facing Outward

Place thicker cuts or portions of meat, poultry, and fish toward the outer edge of the baking dish so they absorb the most microwave energy and the food cooks more evenly.

Shielding

Strips of aluminium foil (which block microwaves) can be placed over the corners or edges of square and rectangular foods to prevent those portions from overcooking. Never use too much foil and make sure the foil is secured to the dish or it may cause arcing in the oven, especially if the foil passes too closely to the walls of the oven during rotation.

Elevating

Thick or dense foods can be elevated so that microwaves can be absorbed by the underside and center of the foods.

Piercing

Foods enclosed in a shell, skin or membrane are likely to burst in the oven unless they are pierced prior to cooking. Such foods include yolks and whites of eggs, clams, oysters, potatoes, and other whole vegetables and fruits.

Testing if Cooked

Microwaves cook food quickly, so test food for doneness frequently. Some foods are left in the microwave until completely cooked, but most foods, including meats and poultry, should be removed from the oven while still slightly undercooked and allowed to finish cooking during standing time. The internal temperature of foods will rise between 5 °F (3 °C) and 15 °F (8 °C) during standing time.

Microwave Power Levels

This upper oven is equipped with 10 power levels to give you maximum flexibility and control over cooking. See the table for suggested power levels for various foods.

Microwave Power Levels Chart

Power Level	Use
10	<ul style="list-style-type: none"> Boiling water. Browning ground beef. Making candy. Cooking poultry pieces, fish, & vegetables. Cooking tender cuts of meat.
9	<ul style="list-style-type: none"> Reheating rice, pasta, & vegetables.
8	<ul style="list-style-type: none"> Reheating prepared foods quickly. Reheating sandwiches.
7	<ul style="list-style-type: none"> Cooking egg, milk and cheese dishes. Melting chocolate.
6	<ul style="list-style-type: none"> Cooking veal. Cooking whole fish. Cooking puddings and custard.
5	<ul style="list-style-type: none"> Cooking ham, whole poultry and lamb. Cooking rib roast and sirloin tip.
4	<ul style="list-style-type: none"> Thawing meat, poultry and seafood.
3	<ul style="list-style-type: none"> Cooking less tender cuts of meat. Cooking pork chops and roasts.
2	<ul style="list-style-type: none"> Taking chill out of fruit. Softening butter.
1	<ul style="list-style-type: none"> Keeping casseroles and main dishes warm. Softening butter and cream cheese.

Cooking at High Power Level

- 1 Turn the Oven Mode knob to select the Microwave mode.
- 2 Touch numbers to set the cook time.
- 3 Touch **Start** to start cooking.
 - When the cook time is over a melody sounds and **End of Cooking** displays.

Cooking at Lower Power Levels

HIGH power cooking does not always give the best results with foods that need slower cooking, such as roasts, baked goods, or custards. The oven has 9 power settings in addition to HIGH.

- 1 Turn the Oven Mode knob to select the Microwave mode.
- 2 Set the cook time in the display.
- 3 Set the power level in the display.
- 4 Touch **Start** to start cooking.
 - When the cook time is over a melody sounds and **End of Cooking** displays.

To Stop Cooking

- 1 Touch **Stop** in the display and select Yes, or turn the Mode knob to the **OFF** position.

+30 seconds

Use this to quickly add 30 seconds to microwave cooking time.

To use, touch +30 sec at the bottom left side of the screen.

Defrost

The oven has 4 preset defrost cycles. The defrost feature provides the best defrosting method for frozen foods. The Defrost Table shows the suggested defrost cycle for various foods.

The Defrost function conveniently chimes partway through the defrost cycle to remind you to check, turn over, separate, or rearrange the food for best results.

- 1 **Meat**
- 2 **Poultry**
- 3 **Fish**
- 4 **Bread**

Setting the Defrost Function

- 1 Turn the Oven Mode knob to select the Defrost mode.
- 2 Set the type of food in the display.
- 3 Set the weight in the display.
- 4 Touch **Start** to start defrosting.

To Stop Cooking

- 1 Touch **Stop** in the display, and select Yes, or turn the Mode knob to **OFF** position.

NOTE

- The countdown appears in the display after **START** is pressed. The oven chimes once, partway through the defrost cycle.
- At the chime, open the oven door and turn the food over. Remove any food that has thawed. Return the still frozen items to the oven and touch **Start** to complete the defrost cycle.

Weight Conversion Table

Most food weights are given in pounds and ounces. If using pounds, food weights must be entered into Auto Defrost in pounds and tenths of pounds (decimals).

Use the following table if necessary to convert food weights to decimals.

Equivalent Weight	
OUNCES	DECIMAL WEIGHT
1.6	.10
3.2	.20
4.8	.30
6.4	.40
8.0	.50 One-Half Pound
9.6	.60
11.2	.70
12.8	.80
14.4	.90
16.0	1.00 One Pound

Defrost Table

Category	Food to be Defrosted
Meat 0.1 - 6.0 lbs	<p>Beef Ground beef, round steak, stew cubes, tenderloin steak, pot roast, rib roast, rump roast, chuck roast, hamburger patties</p> <p>Lamb Chops, rolled roast</p> <p>Pork Chops, hotdogs, spareribs, country-style ribs, rolled roast, sausage</p> <p>Veal Cutlets (1 lb, ½ inch thick)</p> <p>When BEEP, turn food over. After defrosting, let stand for 5 - 15 minutes.</p>
Poultry 0.1 - 6.0 lbs	<p>Poultry Whole, cut-up, breast (boneless). Rinse chicken cavity with tap water and let stand for 60 minutes after cooking for better results.</p> <p>Cornish Hens Whole</p> <p>Turkey Breast</p> <p>When BEEP, turn food over. After defrosting, let stand for 60 minutes.</p>
Fish 0.1 - 4.0 lbs	<p>Fish Fillets, whole steaks</p> <p>Shellfish Crab meat, lobster tails, shrimp, scallops</p> <p>When BEEP, turn food over. After defrosting, let stand for 5 - 10 minutes.</p>
Bread 0.1 - 2.0 lbs	<p>Sliced bread, buns, baguettes, etc. Separate slices and place between paper towels or on flat plate.</p> <p>When BEEP, turn food over. After defrosting, let stand for 1 - 2 minutes.</p>

Defrosting Tips

- When using Defrost, the weight to be entered is the net weight in pounds and tenths of pounds (the weight of the food minus the container).
- Before starting, remove the metal twist-ties which often come with frozen food bags, and replace them with strings or elastic bands.
- Open containers such as cartons before they are placed in the oven.
- Remove fish, shellfish, meat, and poultry from its original wrapping paper or plastic package. Otherwise, the wrap will hold steam and juice close to the foods, which can cause the outer surface of the foods to cook.
- If food is foil wrapped, remove foil and place the food in a suitable container.
- Slit the skins, if any, of frozen food such as sausage.
- Bend plastic pouches of food to ensure even defrosting.
- Place foods in a shallow container or in a microwave roasting dish to catch the drippings.
- Always underestimate defrosting time. Food should still be somewhat icy in the center when removed from the oven. If defrosted food is still icy in the center, return it to the upper oven for more defrosting.
- The length of defrosting time varies according to how solidly the food is frozen.
- Depending on the shape of the food, some areas may defrost more quickly than others.
- The shape of the package affects how quickly food will defrost. Shallow packages will defrost more quickly than a deep block.
- As food begins to defrost, separate the pieces to defrost them more easily.
- Turn over food during defrosting or standing time. Break apart and remove food as required.
- For best results, shape ground meat into the form of a doughnut before freezing. When defrosting, scrape off thawed meat when the beep sounds and continue defrosting.
- Use small pieces of aluminum foil to shield parts of food such as chicken wings, leg tips, fish tails, or areas that start to get warm. Make sure the foil does not touch the sides, top, or bottom of the oven. The foil can damage the oven lining.
- For better results, let food stand after defrosting.

Sensor Operation

Sensor Cook reheats favorite foods without selecting cooking times and power levels.

The oven automatically determines required cooking time for each food item. When the internal sensor detects a certain amount of humidity coming from the food, it tells the oven how much longer to heat. The display shows the remaining heating time. For best results when sensor cooking, follow these recommendations.

- Food cooked with the sensor system should be at normal storage temperature.
- The glass tray and the outside of the container should be dry to assure best cooking results.
- Foods should always be covered loosely with microwavable plastic wrap, waxed paper, or a lid.
- Do not open the door during the sensing time. When sensing time is over, the oven beeps and the remaining cooking time will appear in the display window. At this time you can open the door to stir, turn, or rearrange the food.

Appropriate containers and coverings help assure good sensor cooking results.

- Always use microwavable containers and cover them with lids or vented plastic wrap.
- Never use tight-sealing plastic covers. They can prevent steam from escaping and cause food to overcook.
- Match the amount to the size of the container. Fill containers at least half full for best results.
- Be sure the outside of the cooking container and the inside of the upper oven are dry before placing food in the oven. Beads of moisture turning into steam can mislead the sensor.

Using Sensor Cook

Use Sensor Cook to heat common microwave-prepared foods without needing to program times and power levels. Sensor Cook has preset programs for 9 food categories. See the Sensor Cook table for more information.

Setting the Sensor Cook Function

- 1 Turn the Oven Mode knob to select the Sensor Cook mode.
- 2 Touch a category to filter the options.
- 3 Touch **Start**.
 - When the cook time is over a melody sounds and **End of Cooking** displays.

To Stop Cooking

- 1 Touch **Stop** in the display and select Yes, or turn the Mode knob to the **OFF** position.

Sensor Cook Table

- The Sensor Cook function has preprogrammed settings to automatically sensor reheat certain foods.

Category	Weight	Cookware	Food Temp.	Instructions
1. Beverage	1-2 cups (240 ml per cup)	Mug or microwave-safe cup on the glass tray	Room	Use microwave safe mug or cup without covering. After cooking, stir to complete reheating. (Be careful! The beverage will be very hot. Sometimes liquids heated in cylindrical containers will splash out unexpectedly when the cup is moved.)
2. Casserole	10-20 oz	Microwave-safe bowl on the glass tray	Refrigerated	Use microwave safe bowl. Cover container with vented plastic wrap. After cooking, let stand for 3 minutes.
3. Chicken	16-20 oz	Microwave-safe bowl on the glass tray	Refrigerated	Use microwave safe bowl. Cover container with vented plastic wrap. After cooking, let stand for 3 minutes.
4. Pasta	½-2 cups	Microwave-safe bowl on the glass tray	Refrigerated	Use microwave safe bowl. Cover container with vented plastic wrap. After cooking, let stand for 3 minutes.
5. Pizza	1-3 slices	Microwave-safe plate on the glass tray	Refrigerated	This is a reheat function for leftover pizza. Use microwave safe plate without covering.
6. Plate of food	1 serving	Microwave-safe plate on the glass tray	Refrigerated	Use microwave safe plate. Cover container with vented plastic wrap. After cooking, let stand for 3 minutes.
7. Rice	½-2 cups	Microwave-safe bowl on the glass tray	Refrigerated	Use microwave safe bowl. Cover container with vented plastic wrap. After cooking, let stand for 3 minutes.
8. Soup	1-4 cups	Microwave-safe bowl on the glass tray	Room	Use microwave safe bowl. Cover container with vented plastic wrap. After cooking, let stand for 3 minutes.
9. Vegetable	1-4 cups	Microwave-safe bowl on the glass tray	Refrigerated	Use microwave safe bowl. Cover container with vented plastic wrap. After cooking, let stand for 3 minutes.

Convection Bake

During Convection Bake, a heating element is used to raise the temperature of the air inside the oven. Convection cooking temperature ranges from 100 °F to 450 °F.

It is best to preheat the oven when convection cooking.

NOTE

Reduce oven temperature by 25 °F from the temperature recommended on packaged foods. The baking time may vary according to the food condition or individual preference.

Setting the Convection Bake Function

- 1 Turn the Oven Mode knob to select the Conv. Bake mode.
- 2 Set the temperature. Turn the Temp knob clockwise/counterclockwise, scroll through the numbers on the display, or touch the number pad icon to enter the numbers directly.
- 3 If desired, set the cook time.
- 4 Touch **Start**. The oven starts to preheat.
- 5 If the cook time is set, the remaining time appears in the display.
- 6 A chime sounds once preheating is complete.
- 7 A chime sounds at the end of the set cook time and a notification appears in the display. Open the oven door and remove the food.

Changing the Convection Bake Settings

- 1 Touch **Edit** in the display to bring up the Cook Settings screen.
- 2 Adjust the settings.
- 3 Touch **Start**.

To Stop Cooking

- 1 Touch **Stop** in the display and select Yes, or turn the Mode knob to the **OFF** position.

NOTE

- When the oven reaches the set preheat temperature, a melody will sound. The oven automatically holds that temperature for 30 minutes.
- The oven temperature drops very quickly when the door is opened; however, this should not prevent food from being fully cooked during normal cooking time.

Broil

This feature will allow you to brown and crisp food quickly. There is no need for preheating.

Setting the Broil Function

- 1 Turn the Oven Mode knob to select the Broil mode.
- 2 Set the cook time in the display.
- 3 Touch **Start**. The oven begins to heat.

Changing the Broil Settings

- 1 Touch **Edit** in the display to bring up the **Cook Settings** screen.
- 2 Adjust the settings.
- 3 Touch **Start**.

To Stop Cooking

- 1 Touch **Stop** in the display and select Yes, or turn the Mode knob to the **OFF** position.



CAUTION

Always use oven gloves when removing the food and accessories after cooking as the oven & accessories will be very hot.

NOTE

For best results, use the rack when broiling in the upper oven.

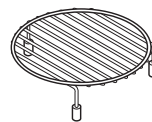

Rack

Speed Cook

This feature uses power from a halogen light, heaters, and microwaves simultaneously to allow quick cooking.

NOTE

Power levels only can be selected from 1 to 4. Each power level gives you heater power and microwave energy for a certain percentage of the time.



CAUTION

When using Speed Cook function, remember that the oven, door and dishes will be very hot.

Setting the Speed Convection Function

Use this mode for roasted meat, roasted chicken, roasted vegetables, frozen pizza, cake, pies and breads.

- 1 Turn the Oven Mode knob to select the Speed Cook mode.
- 2 Touch **SPEED CONVECTION**.
- 3 Set the power level in the display.
- 4 Set the temperature. Turn the Temp knob clockwise/counterclockwise, scroll through the numbers on the display, or touch the number pad icon to enter the numbers directly.
- 5 Set the cook time. Touch the arrow key on the right side of the display to set the cook time.
- 6 Touch **Start**. The oven begins to heat.

Setting the Speed Broil Function

Use this mode for steaks, chicken fillets, fish or seafood.

- 1 Turn the Oven Mode knob to select the Speed Cook mode.
- 2 Touch **Speed Broil**.
- 3 Set the power level in the display.
- 4 Set the cook time in the display.
- 5 Touch **Start**. The oven begins to heat.

Changing the Speed Cook Settings

- 1 Touch **Edit** in the display to bring up the **Cook Settings** screen.
- 2 Adjust the settings.
- 3 Touch **Start**.

To Stop Cooking

- 1 Touch **Stop** in the display and select Yes, or turn the Mode knob to the **OFF** position.

Auto Cook

Use Auto Cook to heat common prepared foods without selecting cooking times and power levels. Auto Cook has preset programs for 28 food functions.

Setting Auto Cook Function

- 1 Turn the Oven Mode knob to select Auto Cook mode.
- 2 Touch a **category** to filter the options.
- 3 Scroll through or tap the letters to find and select an item.
- 4 Follow the recommendations in the display regarding accessories.
- 5 Touch **Start**.

Auto Cook Table

Category	Weight	Cookware	Food Temp.	Instructions
1. Bacon (regular sliced)	3-4 5-6 slices	Microwave-safe bacon rack or plate on the glass tray.	Refrigerated	Place bacon slices on a microwave rack for best results. Use a plate lined with paper towels if rack is not available.
2. Bagels (frozen)	1, 2-3 bagels	Metal tray	Frozen	
3. Baked potatoes (7-9 oz/ea)	1, 2, 3-4 potatoes	Metal tray	Room	Pierce each potato several times with a fork.
4. Brownie	8" X 8" 9" X 13"	Microwave-safe bowl on the glass tray	Room	Spray microwave-safe glass or silicone bakeware with cooking spray. Pour batter into bakeware, spreading it evenly. After cooking, Allow to rest for a few minutes.
5. Cod fillets (1 lb)	-	Metal tray	Refrigerated	Brush with oil and season with salt and pepper. Turn food over at the beep.
6. Corn dog (frozen)	1-2, 3-4	Metal tray	Frozen	
7. Fresh vegetable	4-6, 7-9, 10-12, 13-15, 16-20 oz	Microwave-safe bowl on the glass tray	Refrigerated	Add water according to the quantity. <ul style="list-style-type: none"> • 4-12 oz : add 2 tbsp water • 13-20 oz : add 4 tbsp water Cover with vented plastic wrap. After cooking, stir and let stand for 3 minutes.
8. Frozen chicken nuggets	1-2, 3-4 servings (3.5 oz/100 g per serving)	Metal tray	Frozen	Turn food over at the beep.
9. Frozen chicken wings	1-2, 3-4 servings (3.5 oz/100 g per serving)	Metal tray	Frozen	Turn food over at the beep.
10. Frozen fries	1-2, 3-4 servings (3.5 oz/100 g per serving)	Metal tray	Frozen	Turn food over at the beep.
11. Frozen pizza (regular crust)	Individual (6") Regular (12")	Metal tray	Frozen	
12. Frozen Pretzels	1, 2, 3-4 pretzels	Metal tray	Frozen	
13. Frozen Vegetable	4-6, 7-9, 10-12, 13-15, 16-20 oz	Microwave-safe bowl on the glass tray	Frozen	Add water according to the quantity. <ul style="list-style-type: none"> • 4-12 oz : add 2 tbsp water • 13-20 oz : add 4 tbsp water Cover with vented plastic wrap. After cooking, stir and let stand for 3 minutes.
14. Frozen Garlic Bread	1-2, 3-4, 5-6 pieces	Metal tray	Frozen	Turn food over at the beep.

Category	Weight	Cookware	Food Temp.	Instructions												
15. Hamburger (1/2" thick)	2, 3-4, 5-6 patties	Metal tray	Refrigerated	Turn food over at the beep.												
16. Lamb chops (1/2" thick, 6-7 oz)	1, 2, 3-4 chops	Metal tray	Refrigerated	Brush with oil and season with salt and pepper. Turn food over at the beep.												
17. Meat loaf (9" X 5")	-	Microwave-safe glass or silicone bakeware on the glass tray	Refrigerated	<p>Ingredients</p> <table border="1"> <tr> <td>Ground meat</td> <td>800 g</td> </tr> <tr> <td>Egg (refrigerating temp.)</td> <td>115 g</td> </tr> <tr> <td>Salt</td> <td>2 g</td> </tr> </table> <p>Cooking Place meat mixture into microwave-safe 9"x5" glass or silicone bakeware.</p>	Ground meat	800 g	Egg (refrigerating temp.)	115 g	Salt	2 g						
Ground meat	800 g															
Egg (refrigerating temp.)	115 g															
Salt	2 g															
18. Nachos	1-3, 4-6 servings (8 ea / 1 serving)	Metal tray	Room													
19. Oatmeal	1, 2 servings	Large microwave-safe bowl on the glass tray	Room	<p>Ingredients</p> <table border="1"> <thead> <tr> <th></th> <th>1 serving</th> <th>2 servings</th> </tr> </thead> <tbody> <tr> <td>Oats</td> <td>½ cup (40 g)</td> <td>1 cup (80 g)</td> </tr> <tr> <td>Water or Milk</td> <td>1 cup (230 g)</td> <td>1 ½ cups (345 g)</td> </tr> <tr> <td>Salt (Optional)</td> <td>Dash</td> <td>1/8 tsp</td> </tr> </tbody> </table> <p>Cooking Combine water or milk, salt and oats in a large microwave-safe bowl. Cover with vented plastic wrap. After cooking, let stand for 3 minutes.</p>		1 serving	2 servings	Oats	½ cup (40 g)	1 cup (80 g)	Water or Milk	1 cup (230 g)	1 ½ cups (345 g)	Salt (Optional)	Dash	1/8 tsp
	1 serving	2 servings														
Oats	½ cup (40 g)	1 cup (80 g)														
Water or Milk	1 cup (230 g)	1 ½ cups (345 g)														
Salt (Optional)	Dash	1/8 tsp														
20. Pork chops (1/2" thick, 6-7 oz)	1, 2, 3-4 chops	Metal tray	Refrigerated	Brush with oil and season with salt and pepper. Turn food over at the beep.												
21. Quinoa	1, 2 servings	Large microwave-safe bowl on the glass tray	Room	<p>Ingredients</p> <table border="1"> <thead> <tr> <th></th> <th>1 serving</th> <th>2 servings</th> </tr> </thead> <tbody> <tr> <td>Quinoa</td> <td>½ cup (40 g)</td> <td>1 cup (80 g)</td> </tr> <tr> <td>Water or Milk</td> <td>1 cup (230 g)</td> <td>1 ½ cups (345 g)</td> </tr> <tr> <td>Salt (Optional)</td> <td>Dash</td> <td>1/8 tsp</td> </tr> </tbody> </table> <p>Cooking Combine water or milk, salt and quinoa in a large microwave-safe bowl. Cover with vented plastic wrap. After cooking, let stand for 3 minutes.</p>		1 serving	2 servings	Quinoa	½ cup (40 g)	1 cup (80 g)	Water or Milk	1 cup (230 g)	1 ½ cups (345 g)	Salt (Optional)	Dash	1/8 tsp
	1 serving	2 servings														
Quinoa	½ cup (40 g)	1 cup (80 g)														
Water or Milk	1 cup (230 g)	1 ½ cups (345 g)														
Salt (Optional)	Dash	1/8 tsp														
22. Ribeye steak (1" thick, 14-15 oz)	1, 2 steaks	Metal tray	Refrigerated	Brush with oil and season with salt and pepper. Turn food over at the beep.												

32 OPERATION

Category	Weight	Cookware	Food Temp.	Instructions		
23. Rice	½, 1 cup	Deep and large microwave-safe bowl on the glass tray	Room	Ingredients		
					½ cup	1 cup
				Rice	½ cup (96 g)	1 cup (192 g)
				Water	1 cup (230 g)	2 cups (460 g)
				Salt	Optional	
				Cooking Cover with vented plastic wrap. After cooking, let stand for 5-10 minutes.		
24. Salmon steak (1" thick)	1, 2, 3-4 steaks	Metal tray	Refrigerated	Brush with oil and season with salt and pepper. Turn food over at the beep.		
25. Sausage	1-6, 7-14 links	Metal tray	Refrigerated	Turn food over at the beep.		
26. Sirloin steak (1" thick, 18-21 oz)	1, 2 steaks	Metal tray	Refrigerated	Brush with oil and season with salt and pepper. Turn food over at the beep.		
27. Tenderloin	¾, 1 ½ lb	Metal tray	Refrigerated	Brush with oil and season with salt and pepper. Turn food over at the beep.		
28. Canned vegetable	4-6, 7-9, 10-12, 13-15, 16-20 oz	Microwave-safe bowl on the glass tray	Room	Transfer canned vegetables to microwave-safe bowl. Cover with vented plastic wrap. After cooking, stir and let stand for 3 minutes.		

NOTE

- Do not use recycled paper products in the upper oven. They sometimes contain impurities that cause arcing and sparking.
- **NEVER** use paper products in the convection oven.

Soften

The oven uses low power to soften foods such as butter, cream cheese, frosting, and ice cream. See the following table.

To Stop Cooking

- 1 Touch **Stop** in the display and select Yes, or turn the Mode knob to the **OFF** position.

Setting the Soften Function

- 1 Turn the Oven Mode knob to select the Soften/ Melt mode.
- 2 Touch **SOFTEN**.
- 3 Set the type of food in the display.
- 4 Set the weight in the display.
- 5 Touch **Start**.
 - When the cook time is over a melody sounds and **End of Cooking** displays.

Soften Table

Category	Weight	Cookware	Food Temp.	Instructions
1. Butter	½, 1, 2 sticks	Microwave-safe dish on the glass tray	Refrigerated	Butter will be at room temperature and ready for use in a recipe.
2. Cream cheese	3, 8 oz	Microwave-safe dish on the glass tray	Refrigerated	Cream cheese will be at room temperature and ready for use in a recipe.
3. Frosting (16 oz)	-	Microwave-safe bowl on the glass tray	Refrigerated	Frosting will be at room temperature and ready for use in a recipe.
4. Ice cream	1 pint, 1 quart	Glass tray	Frozen	Remove lid and cover. Ice cream will be soft enough to make scooping easier.

Melt

The oven uses low power to melt foods such as butter, caramel, cheese, chocolate, and marshmallows.

See the following table.

To Stop Cooking

- 1 Touch **Stop** in the display and select Yes, or turn the Mode knob to the **OFF** position.

Setting the Melt Function

- 1 Turn the Oven Mode knob to select the Soften/ Melt mode.
- 2 Touch **MELT**.
- 3 Set the type of food in the display.
- 4 Set the weight in the display.
- 5 Touch **Start**.
 - When the cook time is over a melody sounds and **End of Cooking** displays.

Melt Table

Category	Weight	Cookware	Food Temp.	Instructions
1. Butter	½, 1, 2 sticks	Microwave-safe bowl on the glass tray	Refrigerated	After cooking, stir to complete melting.
2. Caramel	4, 8, 12 oz	Microwave-safe bowl on the glass tray	Room	After cooking, stir to complete melting.
3. Cheese	4, 8, 12 oz	Microwave-safe bowl on the glass tray	Refrigerated	Use processed cheese food only. Cut into cubes. After cooking, stir to complete melting.
4. Chocolate	4, 8, 12 oz	Microwave-safe bowl on the glass tray	Room	Chocolate chips or squares of baking chocolate may be used. After cooking, stir to complete melting.
5. Marshmallow	5, 10 oz	Microwave-safe bowl on the glass tray	Room	After cooking, stir to complete melting.

Warm

The WARM function maintains an oven temperature of less than 230°F. This function should not be used to reheat cold food. The Warm function keeps cooked food warm for serving up to 3 hours after cooking has finished. After 3 hours the WARM function shuts the oven OFF automatically.

Setting the Warm Function

- 1 Turn the Oven Mode knob to select the Warm mode.
- 2 Select the temperature level: Low, Medium, or High.
- 3 Select the type: moist, crisp.
- 4 Touch **Start** to start warming.

To Stop Cooking

- 1 Touch **Stop** in the display and select Yes, or turn the Mode knob to the **OFF** position.

NOTE

- Low = 140°-160°F (60°-71°C)
Medium = 160°-195°F (71°-91°C)
High = 195°-230°F (91°-110°C)
- The Warm function is intended to keep food warm. Do not use it to cool food down.
- It is normal for the fan to operate during the Warm function.

Proof

This feature maintains a warm oven for rising yeast leavened products before baking.

Setting the Proof Function

- 1 Turn the Oven Mode knob to select the **Proof** mode.
- 2 Touch **Start** to start proofing.

To Stop Cooking

- 1 Touch **Stop** in the display and select Yes, or turn the Mode knob to the **OFF** position.

NOTE

- To avoid lowering the oven temperature and lengthening proofing time, do not open the oven door unnecessarily.
- Check bread products early to avoid over-proofing.
- Do not use the proofing mode for warming food or keeping food hot. The proofing oven temperature is not hot enough to hold foods at safe temperatures. Use the WARM feature to keep food warm.
- Proofing will not operate if the oven is too hot. Allow the oven to cool before proofing.

Popcorn

Setting the Popcorn Function

- 1 Turn the Oven Mode knob to select the Popcorn mode.
- 2 Touch **Start**.
The Popcorn function starts.

To Stop Cooking

- 1 Touch **Stop** in the display and select Yes, or turn the Mode knob to the **OFF** position.

NOTE

- Only pop popcorn in a microwave-safe container or commercial packages designed for microwave ovens.
- Never try to pop popcorn in a paper bag that is not microwave-approved.
- If popcorn bag size is not known, follow manufacturers' instructions and do not use this feature.
- Prepare only one bag at a time.
- Do not use popcorn popping devices in upper oven with this feature.
- Do not leave oven unattended while popping corn.
- Do not attempt to reheat or cook any unpopped kernels.
- Do not reuse bag. Overcooking can result in an oven fire.

CAUTION

Never use a brown paper bag for popping corn.



When popping prepackaged popcorn, place the bag carefully in the oven so it does not touch the walls as it rotates. Fold the ends of the bag up and toward the center of the bag as shown.

Using the Lower Oven

Before Using the Oven

NOTE

- The temperature registered by an oven thermometer may differ from the actual set oven temperature.
- It is normal for the convection fan to run while preheating during a regular bake cycle.
- The convection fan motor may run periodically during a regular bake cycle.

Lower Oven Light

The interior oven light automatically turns on when the door is opened. Touch **Lower Light** to manually turn the lower oven light on. The lamp of the lower oven will turn off after 2 minutes and 30 seconds to save power.

- 1 Touch **Lower Light** to turn the lower oven light on or off.

Using Heavy Duty Oven Racks

The racks have a turned-up back edge that prevents them from being pulled completely out of the oven cavity.



CAUTION

- Replace oven racks before turning the oven on to prevent burns.
- DO NOT cover the racks with aluminum foil, or any other material, or place anything on the bottom of the oven. Doing so will result in poor baking and may damage the oven bottom.
- Only arrange oven racks when the oven is cool.
- Do not place objects heavier than 33 lb (15 kg) on the racks. Do not place heavy objects on the corners of the racks. Doing so can damage the racks.

Removing the Racks

- 1 While wearing oven mitts, grasp the oven rack.
- 2 Pull the rack straight out until it stops.
- 3 Lift up the front of the rack.
- 4 Pull out the rack.

Replacing the Racks:

- 1 While wearing oven mitts, place the end of the rack on the support.
- 2 Tilt the front end of the rack up.
- 3 Push the rack in.
- 4 Check that the rack is properly in place.

Rack and Pan Placement

If cooking on two racks:

Place standard oven racks in positions 2 and 4.

Place the cookware as shown below. If baking with more than one pan, place the pans so that each one has at least 1" to 1 ½" of air space around them.

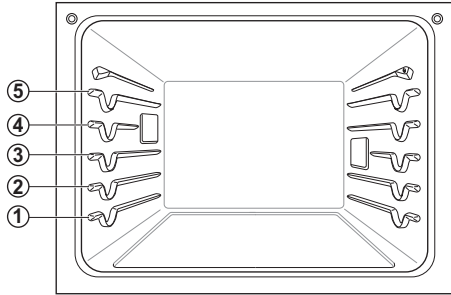

Multiple Rack Baking

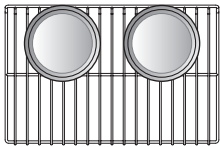

(Position 2)

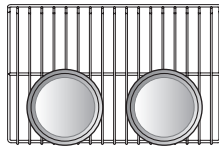

(Position 4)

Single Rack Baking

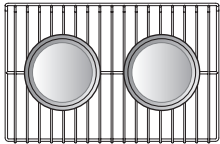

Type of Food	Rack Position
Angel food cake, frozen pies	3
Bundt or pound cakes	2
Biscuits, muffins, brownies, cookies, cupcakes, layer cakes, pies	3
Casseroles	2
Turkey, roasts, or ham	1
Frozen pizza	3
Roast chicken	2

When baking cakes and cookies on multiple racks, use the Convection Bake mode and place racks in positions 2 and 4.

Oven Vent

- Areas near the vent may become hot during operation and may cause burns.
- Do not block the vent opening at the bottom of the oven.
- Avoid placing plastics near the vent as heat may distort or melt the plastic.
- It is normal for steam to be visible when cooking foods with high moisture.

Using Gliding Oven Racks

The gliding racks slide in and out on a frame. This keeps heavy cookware level and prevents it from sliding forward when the rack is completely extended.

Installing Gliding Racks

- 1 Start with the rack in the closed position. Hold the rack with one hand at the center front and the other hand at the back right corner.
- 2 Carefully insert the rack between the rack guides, and slide it back until the shelf drops into place.

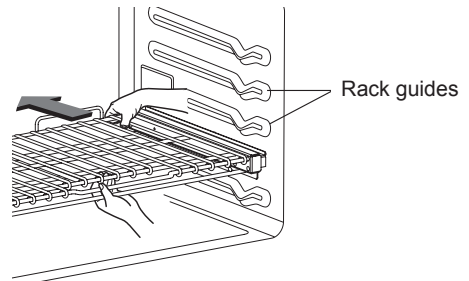

- 3 Once the rack is secured in the back, pull the entire rack forward until the rack locks into place.

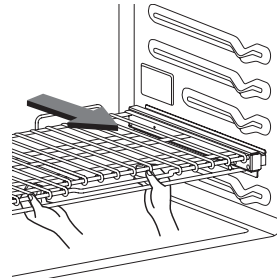

Removing Gliding Racks

- 1 With the rack in the closed position, grasp the front of the rack and frame and lift up. Slowly push the rack towards the back wall until it is free of the rack stop.
- 2 After disengaging the rack stop, lift the back of the rack and pull the rack and frame out between the rack guides.

CAUTION

- Place oven racks in the desired location before turning on the oven to avoid burns.
- Do not cover the racks with aluminum foil, or any other material, or place anything on the bottom of the oven. Doing so will result in poor baking and may damage the oven bottom.

Bake

Use BAKE to prepare foods such as pastries, breads and casseroles. The oven can be programmed to bake at any temperature from 170°F (80°C) to 550°F (285°C). The default temperature is 350°F (175°C).

Setting the BAKE mode

- 1 Turn the Oven Mode knob to select the Bake mode.
- 2 Set the oven temperature. Turn the Temp knob clockwise/counterclockwise, scroll through the numbers on the display, or touch the number pad icon  to enter the numbers directly.
- 3 If desired, set the cook time and delayed start time using the same method. Touch the arrow key on the right side of the display to see the delayed start time settings.
- 4 Touch **Start**. The oven starts to preheat.
- 5 If the cook time is set, the remaining time appears in the display. If a delayed start time is set, the start time appears in the display.
- 6 A chime sounds once preheating is complete.
- 7 A chime sounds at the end of the set cook time and a notification appears in the display. Open the oven door and remove the food.

- If no cook time is set, the oven turns off automatically after 12 hours.

Changing the Cook Settings

- 1 Touch **Edit** in the display to bring up the Cook Settings screen.
- 2 Adjust the settings using the number pad or scroll function.
- 3 Touch **Start**.

To Stop Cooking

- 1 Touch **Stop** in the display, and select Yes, or turn the Mode knob to **OFF** position.

NOTE

It is normal for the convection fan to operate periodically throughout a normal bake cycle in the oven. This is to ensure even baking results.

Baking Tips

Follow the recipe or convection food directions for baking temperature, time, and rack position. Baking time and temperature will vary depending on the ingredients, size, and shape of the baking pan used.

- For best results, food should be placed on a single rack with at least 1" to 1 1/2" of air space between the pans and oven walls.
- Check for doneness at the minimum time.
- Use metal bakeware (with or without a nonstick finish), heatproof glass-ceramic, ceramic or other bakeware recommended for oven use.
- Dark metal pans or nonstick coatings will cook faster with more browning. Insulated bakeware will slightly lengthen the cooking time for most foods.

NOTE

The oven bottom has a porcelain-enamel finish. To make cleaning easier, protect the oven bottom from excessive spillovers by placing a cookie sheet on the rack below the rack you are cooking on.

This is particularly important when baking a fruit pie or other foods with a high acid content. Hot fruit fillings or other foods that are highly acidic may cause pitting and damage to the porcelain-enamel surface and should be wiped up immediately.

Convection Modes

Convection Bake and Convection Roast use a fan to circulate heat evenly within the oven. This improves heat distribution and allows for even cooking and excellent results whether cooking on one rack or multiple racks.

The convection modes on the oven can be programmed to cook at temperatures from 170°F (80°C) to 550°F (285°C). The default temperature is 350°F (175°C).

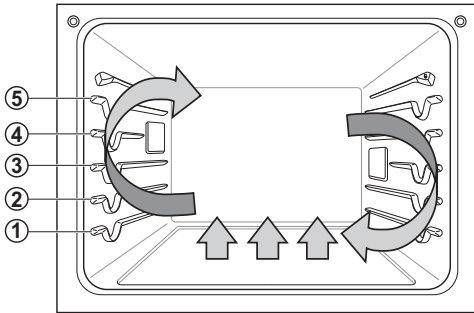

Using Convection

- 1 Turn the Oven Mode knob to select the Conv. Bake or Conv. Roast mode.
 - 2 Set the temperature. Turn the Temp knob clockwise/counterclockwise, scroll through the numbers on the display, or touch the number pad icon  to enter the numbers directly.
 - 3 If desired, set the cook time and delayed start time using the same method. Touch the arrow key on the right side of the display to see the delayed start time settings.
 - 4 Touch **Start**. The oven starts to preheat.
 - 5 If the cook time is set, the remaining time appears in the display. If a delayed start time is set, the start time appears in the display.
 - 6 A chime sounds once preheating is complete.
 - 7 A chime sounds at the end of the set cook time and a notification appears in the display. Open the oven door and remove the food.
- If no cook time is set, the oven turns off automatically after 12 hours.

Changing the Cook Settings

- 1 Touch **Edit** in the display to bring up the Cook Settings screen.
- 2 Adjust the settings using the number pad or scroll function.
- 3 Touch **Start**.

To Stop Cooking

- 1 Touch **Stop** in the display, and select Yes, or turn the Mode knob to **OFF** position.

NOTE

The oven fan runs while convection baking and convection roasting. The fan stops when the door is opened. In some cases, the fan may shut off during a convection bake cycle.

Tips for Convection Baking

- Use Convection Bake for faster and more even multiple-rack cooking of pastries, cookies, muffins, biscuits, and breads of all kinds.
- Bake cookies and biscuits on pans with no sides or very low sides to allow heated air to circulate around the food. Food baked on pans with a dark finish will cook faster.
- When using Convection Bake with a single rack, place the gliding rack in position 3. If cooking on multiple racks, place the gliding racks in positions 2 and 4 (for two racks).
- Multiple oven rack cooking may slightly increase cook times for some foods.
- Cakes, cookies and muffins have better cooking results when using multiple racks.

Convection Roast

The Convection Roast feature is designed to give optimum roasting performance. Convection Roast combines cooking with the convection fan to roast meats and poultry. The heated air circulates around the food from all sides, sealing in juices and flavors. Foods are crispy brown on the outside while staying moist on the inside. Convection roasting is especially good for large tender cuts of meat, uncovered.

NOTE

The heating elements and a fan turn off immediately when the door is opened. They turn on again approximately 1 second after the door is closed. Touch **Stop** in the display or Turn the Oven Mode knob to **OFF** position to cancel Convection Bake and Convection Roast at any time.

Tips for Convection Roasting

Use a broiler pan and grid when preparing meats for Convection roast, RapidHeat Roast and Broil. The broiler pan catches grease spills and the grid helps prevent grease splatters.

- 1 Place the oven rack in position 1 or 2. See the Rack and Pan Placement.
- 2 Place the grid in the broiler pan.
- 3 Place the broiler pan on the oven rack.

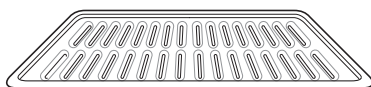

Grid

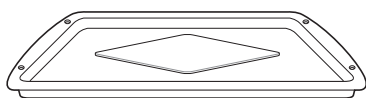

Broiler pan



CAUTION

- Do not use a grid without a broiler pan.
- Do not cover the grid with aluminum foil.
- Position food fat side up on the grid.

RapidHeat Roast+

The RapidHeat Roast+ feature is designed to quickly roast poultry. The combination of intense heat from the upper and lower heating elements and heated air from the back heating element results in crispier food and shorter cooking times. The RapidHeat Roast+ is especially good for medium sized poultry (about 3.3 lb.)

The RapidHeat Roast+ feature uses steam to roast poultry with more browning.

NOTE

- The recommended cook time is 55~65 minutes for the oven for a whole chicken weighing 3.3 lb.
- Adjust the cook time according to the weight of the poultry.
- Place the oven rack in position 2.
- RapidHeat Roast+ is designed to reduce the cooking time. There is no need for preheating.
- This function is optimized for poultry, so the cooking temperature cannot be adjusted.
- It is normal for the fan to operate during the RapidHeat Roast+ function.
- If the descaling reminder appears, press OK to run the Descaling function.
- When the temperature rise in the oven, steam may not be visible.
- Take care when opening the oven door during or after steam cooking. Hot steam can cause scalding.
- After any steam cooking cycle, the drying function will run a. It is normal to hear the steam pump running during the drying function.

Setting the RapidHeat Roast+ Function

- 1 Turn the Oven Mode knob to select the **RapidHeat Roast+** mode.
- 2 Touch **Start**.
- 3 If the cook time is set, the remaining time appears in the display. If a delayed start time is set, the start time appears in the display.

- Make sure the steam feeder tank is filled with water before starting the RapidHeat Roast+ mode.
- If no cook time is set, the oven turns off automatically after 12 hours.

Changing the Cook Settings

- 1 Touch **Edit** in the display to bring up the Cook Settings screen.
- 2 Adjust the settings using the number pad or scroll function.
- 3 Touch **Start**.

To Stop Cooking

- 1 Touch **Stop** in the display, and select Yes, or turn the Mode knob to **OFF** position.

Broil

Broiling uses an intense, radiant heat to cook food. Both the inner and outer broil elements heat during full broiling. Only the inner broil element heats during center broiling. The element(s) cycle on and off at intervals to maintain the oven temperature. The meat probe cannot be used with this mode.

Keep the oven door closed while broiling. Let the oven preheat for approximately 5 minutes before cooking food.



CAUTION

- DO NOT use a grid without a broiler pan. Oil can cause a grease fire.
- DO NOT cover the grid and broiler pan with aluminum foil. Doing so will cause a fire.
- Always use a broiler pan and grid for excess fat and grease drainage. This will help to reduce splatter, smoke, and flare-ups.
- Should an oven fire occur, leave the oven door closed and turn the oven off. If the fire continues, throw baking soda on the fire or use a fire extinguisher.
- DO NOT put water or flour on the fire.
 - Flour may be explosive and water can cause a grease fire to spread and cause personal injury.

NOTE

This oven is designed for closed-door broiling. Close the door to set the Broil function. If the door is open, the Broil function can be set, but **DOOR OPEN** appears in the display. Close the door to start the Broil function. If the door is opened during broiling, the broil burner turns off after 5 seconds. The broiler turns back on automatically once the door is closed.

Setting the BROIL Mode

- 1 Place food on the broiler pan grid.
 - 2 Turn the Oven Mode knob to select the **Broil** mode.
 - 3 Scroll to set the desired temperature: Low, Medium, or High. If desired, scroll to set a cook time.
 - 4 If desired, set the cook time and delayed start time using the same method. Touch the arrow key on the right side of the display to see the delayed start time settings.
 - 5 Touch **Start**. If the cook time was set, the remaining time appears in the display. The oven door must be closed to use the Broil function.
 - 6 Let the oven preheat for approximately 5 minutes before cooking the food.
 - 7 If the cook time is set, the remaining time appears in the display. If a delayed start time is set, the start time appears in the display.
 - 8 Touch **STOP** to cancel at any time or when cooking is complete.
- If the cook time is not set, the oven automatically turns off after 3 hours.

Changing the Broil Settings

- 1 Touch **Edit** in the display to bring up the Cook Settings screen.
- 2 Adjust the settings.
- 3 Touch **Start**.

To Stop Broiling

- 1 Touch **Stop** in the display, and select Yes, or turn the Mode knob to **OFF** position.

Smoking

Due to the intense heat associated with broiling, it is normal to experience smoke during the cooking process. This smoke is a natural by-product of searing and should not cause you to worry. If you are experiencing more smoke than you are comfortable with, use the following tips to reduce the amount of smoke in your oven.

- 1 Always use a broiler pan. Do not use saute pans or regular baking sheets for safety reasons.
- 2 NEVER use a broiler pan that is not thoroughly cleaned and at room temperature at the beginning of cooking.
- 3 ALWAYS run your cooktop ventilation system or vent hood during broiling.
- 4 Keep the interior of your oven as clean as possible. Leftover debris from prior meals can burn or catch fire.
- 5 Avoid fatty marinades and sugary glazes. Both of these will increase the amount of smoke you experience. If you would like to use a glaze, apply it at the very end of cooking.
- 6 If you are experiencing significant smoke with any food item, consider:
 - Lowering the broiler to the LO setting.
 - Lowering the rack position to cook the food further away from the broiler.
 - Using the HI broil setting to achieve the level of searing you desire, and then either switching to the LO broil setting, or switching to the BAKE function.
- 7 As a rule, fattier cuts of meat and fish will produce more smoke than leaner items.
- 8 Adhere to the recommended broil settings and cooking guidelines in the chart on the following page whenever possible.

NOTE

The heating element(s) turn off immediately when the door is opened. They turn on again approximately 1 second after the door is closed. Touch **Stop** in the display or turn the Oven Mode knob to **OFF** position to cancel Broil at any time.

Recommended Broiling Guide

The size, weight, thickness, starting temperature, and your preference of doneness will affect broiling times. The following guide is based on meats at refrigerator temperature.

NOTE

Always use a broiler pan and grid when broiling.

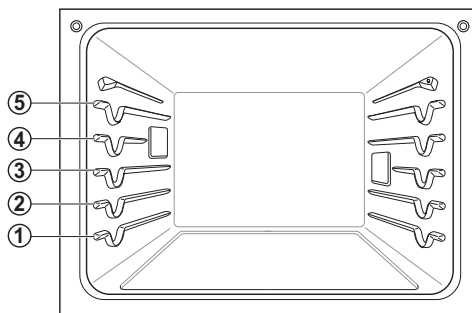
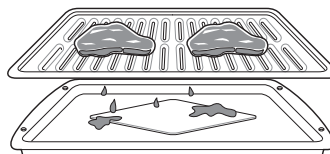

Broiling Chart

Food	Quantity and/ or Thickness	Rack Position	First Side Time (min.)	Second Side Time (min.)	Comments
Ground Beef	1 lb. (4 patties) 1/2 to 3/4" thick	5	4-6	3-4	Space evenly. Up to 9 patties may be broiled at once.
Beef Steaks					Steaks less than 1" thick cook through before browning. Pan frying is recommended. Remove fat.
Rare	1" thick	4	6	2-3	
Medium	1 to 1-1/2 lbs.	4	7	2-3	
Well Done		4	8	3-4	
Rare	1-1/2" thick	4	10	4-6	
Medium	2 to 2-1/2 lbs.	4	12	4-8	
Well Done		4	14	8-10	
Chicken	1 whole cut up 2 to 2-1/2 lbs., split lengthwise 2 Breasts	3 3	20 20	6-8 6-10	Broil skin-side-down first.
Lobster Tails	2-4 10 to 12 oz. each	3	12-14	Do not turn over.	Cut through back of shell. Spread open. Brush with melted butter before broiling and after half of broiling time.
Fish Fillets	1/4 to 1/2" thick	4 or 5	5-6	3-4	Handle and turn very carefully. Brush with lemon butter before and during cooking, if desired.
Ham Slices (precooked)	1/2" thick	4	5	3-5	Increase time 5 to 10 minutes per side for 1-1/2" thick or home-cured ham.
Pork Chops	2 (1/2" thick)	4 or 5	7	6-8	Remove fat.
Well Done	2 (1" thick) about 1 lb.	4 or 5	9-10	7-9	
Lamb Chops					Remove fat.
Medium	2 (1" thick) about 10 to 12 oz.	4	6	4-6	
Well Done		4	8	7-9	
Medium	2 (1-1/2" thick) about 1 lb.	4	11	9	
Well Done		4	13	9-11	
Salmon Steaks	2 (1" thick) 4 (1" thick) about 1 lb.	4 or 5 4 or 5	8 9	3-4 4-6	Grease pan. Brush steaks with melted butter.

Broiling Tips

Beef

- Steaks and chops should always be allowed to rest for 5 minutes before being cut into and eaten. This allows the heat to distribute evenly through the food and creates a more tender and juicy result.
- Pieces of meat that are thicker than two inches should be removed from the refrigerator 30 minutes prior to cooking. This will help them cook more quickly and evenly, and will produce less smoke when broiling. Cooking times will likely be shorter than the times indicated in the Broiling Chart.
- For bone-in steaks or chops that have been Frenched (all meat removed from around the bone), wrap the exposed sections of bone in foil to reduce burning.

Seafood

- When broiling skin-on fish, always use the Medium broil setting and always broil the skin side last.
- Seafood is best consumed immediately after cooking. Allowing seafood to rest after cooking can cause it to dry out.
- It is a good idea to rub a thin coating of oil on the surface of the broiling pan before cooking to reduce sticking, especially with fish and seafood. You can also use a light coating of non-stick pan spray.

Vegetables

- Toss vegetables lightly in oil before cooking to improve browning.

Warm

The WARM mode maintains an oven temperature of 200°F (93°C) or less. Use the Warm mode to keep cooked food at serving temperature for up to three hours after the end of the cooking cycle. Do not use the Warm mode to try to cook food or reheat cold food.

Setting the WARM Mode

- 1 Turn the Oven Mode knob to select the **Warm** mode.
- 2 Scroll to set the desired temperature: Low, Medium, or High. If desired, scroll to set a run time.
- 3 If desired, set the warming time and delayed start time using the same method. Touch the arrow key on the right side of the display to see the delayed start time settings.
- 4 Touch **Start**. If the run time was set, the remaining time appears in the display.
- 5 If the warming time is set, the remaining time appears in the display. If a delayed start time is set, the start time appears in the display.
- 6 Touch **STOP** to cancel at any time or when warming is complete.

NOTE

- The warm feature has three temperature levels: High=200 °F, Med=170 °F, Low=140 °F (High=93.3 °C, Med=76.7 °C, Low=60 °C)

NOTE

- The WARM function is intended to keep food warm. Do not use it to cool food down.

If the cook time is not set, the oven automatically turns off after 3 hours.

Changing the Warm Settings

- 1 Touch **Edit** in the display to bring up the Cook Settings screen.
- 2 Adjust the settings as desired.
- 3 Touch **Start**.

Canceling the Warm Function

- 1 Touch **Stop** in the display, and select Yes, or turn the Mode knob to **OFF** position.

Proof

The Proof feature maintains a warm environment for rising yeast-leavened products before baking.

NOTE

For best results, cover the dough with a cloth or with plastic wrap. (The plastic may need to be anchored underneath the container so the oven fan does not blow it off.)

Setting the PROOF Mode

This feature maintains a warm oven for rising yeast-leavened products before baking.

- 1 Turn the Oven Mode knob to select the **Proof** mode.
- 2 Scroll through the numbers to set a proofing time or touch the number pad icon  to enter the numbers directly.
- 3 If desired, set the cook time and delayed start time using the same method. Touch the arrow key on the right side of the display to see the delayed start time settings.
- 4 Touch **Start**. The remaining proofing time appears in the display.
- 5 If the cook time is set, the remaining time appears in the display. If a delayed start time is set, the start time appears in the display.

- If the proofing time is not set, the oven automatically turns off after 12 hours.

Canceling the Proof Function

- 1 Touch **Stop** in the display, and select Yes, or turn the Mode knob to **OFF** position.

NOTE

- To avoid lowering the oven temperature and lengthening proofing time, do not open the oven door unnecessarily. Check bread products early to avoid over proofing.
- Do not use the proofing mode for warming food or keeping food hot. The proofing oven temperature is not hot enough to keep foods at safe temperatures. Use the WARM feature to keep food warm. Proofing doesn't operate when the oven is above 125°F(52°C). **OVEN IS HOT** shows in the display.

Probe

The probe accurately measures the internal temperature of meat, poultry and casseroles. It should not be used during the broiling, sous vide, steam maintenance, rapid heat roast +, self cleaning, speed cleaning, warming or proofing mode. Always unplug and remove the probe from the oven before removing food. Before using, insert the probe into the center of the thickest part of meat or into the inner thigh or breast of poultry, away from fat or bone. Place food in the oven and connect the meat probe to the jack. Keep the probe as far away from heat sources as possible.

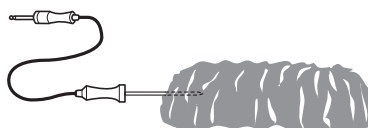

- The probe cannot be used in Broil, Self Clean, SpeedClean™, Warm or Proof modes.
- For thin cuts of meat, insert probe in thickest side of meat.



Recommended Probe Placement Chart

Category	Examples of Food	Probe Placement
Ground Meat & Meat Mixtures	Meatloaf	Insert in the thickest part
	Meatballs	
Fresh Beef, Veal, Lamb	Steaks, Roasts, Chops	Insert in the thickest part, away from bone, fat and gristle
Poultry	Whole Chicken or Turkey	Insert in the thickest part of thigh, avoiding bone
	Poultry Breasts or Roasts	
	Duck, Goose, Pheasant	
	Stuffing (Alone or in Bird)	Insert in the thickest part of the dish
Pork & Ham	Fresh Pork	Insert in the thickest part, away from bone, fat and gristle
	Fresh Ham (Raw)	
	Precooked Ham (Reheat & Serve)	
Leftovers & Casseroles	Leftovers	Insert in the thickest part of the dish
	Casseroles	
Seafood	Whole Fish	Insert in the thickest part of the fish
	Fish Fillet (Side of Fish)	
	Fish Steaks or Portions	

Using the Meat Probe Feature

- 1 Insert the probe into the food.
- 2 Connect the probe to the jack in the oven, "Probe is connected" pops up in the display and the probe icon  appears at the top of the display.
- 3 Turn the Oven Mode knob to select an appropriate cooking mode.
- 4 Set the oven temperature. Turn the Temp knob clockwise/counterclockwise, scroll through the numbers on the display, or touch the number pad icon  to enter the numbers directly. The default probe temperature is 150 °F (65 °C), but can be changed to any temperature between 80 °F (27 °C) and 210 °F (100 °C).
- 5 If desired, set the delayed start time using the same method. Touch the arrow key on the right side of the display to see the additional settings.
- 6 Touch **Start**. If a delayed start time has been set, the start time appears in the display.
- 7 When the set probe temperature is reached, the oven shuts off automatically.

NOTE

Calculating a total cooking time by weight is no longer necessary using this feature. The following chart is recommended for setting the probe temperature.



CAUTION

- Always use an oven mitt to remove the temperature probe. Do NOT touch the broil element.
 - Failure to follow this warning can result in severe personal injury.

Changing the Probe Temperature while Cooking

- 1 Touch **Edit** in the display to bring up the Cook Settings screen.
- 2 Adjust the settings as desired.
- 3 Touch **Start**.

To Stop Cooking

- 1 Touch **Stop** in the display, and select Yes, or turn the Mode knob to **OFF** position.

IMPORTANT NOTE

Touch Stop in the display or turn the Oven Mode knob to OFF position on the display at any time to cancel a cooking operation. To avoid breaking the probe, make sure food is completely defrosted before inserting.



CAUTION

- **Always use an oven mitt to remove the temperature probe. Do not touch the broil element.** Failure to obey this caution can result in severe personal injury.
- **To avoid damage to the meat probe, do not use tongs to pull on the probe when removing it.**
- **Do not store the meat probe in the oven.**

NOTE

- The meat probe can't be used with the Broil, Sous Vide, Steam Maintenance, RapidHeat Roast+, Self Clean, SpeedClean™, Warm, or Proof modes.
- While the meat probe mode is running, **SpeedClean™** does not respond.

Recommended Probe Temperature Chart

Category	Examples of Food	Target Internal Temp.	Desired Doneness
Ground Meat & Meat Mixtures	Meatloaf	160 °F (71 °C)	
	Meatballs	165 °F (74 °C)	
Fresh Beef, Veal, Lamb	Roasts	145 °F (63 °C)	Rare : 120 °F (49 °C) Medium rare : 125 °F (52 °C) Medium : 130 °F (54 °C) Medium well done : 135 °F (57 °C) Well done : 140 °F (60 °C)
Poultry	Whole Chicken or Turkey	165 °F (74 °C)	
	Poultry Breasts or Roasts		
	Duck, Goose, Pheasant		
	Stuffing (Alone or in Bird)		
Pork & Ham	Fresh Pork	145 °F (63 °C)	Well Done: 170 °F (77 °C)
	Fresh Ham (Raw)		Well Done: 160 °F (71 °C)
	Precooked Ham (Reheat & Serve)	140 °F (60 °C)	
Leftovers & Casseroles	Leftovers	165 °F (74 °C)	
	Casseroles		

My Recipes

For frequently used cooking menus, you can combine up to three different temperatures and cooking modes into one recipe card.

Creating My Recipes

- When combining two or more cooking modes, a cooking time or probe temperature must be set before selecting an additional cooking mode.
 - The Probe function cannot be used with the Broil, Sous Vide, RapidHeat Roast+, Warm, and Proof modes
- 1 Turn the Oven Mode knob to select the My Recipes mode.
 - 2 Touch **Create** to make a new recipe card.
 - 3 Select a first cook mode listed in the display and set the desired cook temperature.
 - 4 Touch **Set Cook Time** or **Set Probe**.
 - 5 If there are no additional cooking stages, touch **Done**. To add another cooking stage, set a cooking time or probe temperature for the first stage. Then touch **Add Cook Stage**.
 - 6 Repeat steps 3-5 until all desired cooking stages have been entered. Then touch **Done**.
 - 7 Enter a name for your recipe using the keyboard and touch **Save**.
 - 8 The recipe name is added to the My Recipes menu.

NOTE

- If the probe was inserted in the oven jack to add a probe temperature, remember to remove it.
- After the steam mode is used for 8 hours, a reminder to descale the product appears in the display the next time the steam mode is selected. You will not be able to use the steam mode until the Descaling function is run. To avoid this delay, run the Descaling function after every 2-3 uses of the steam mode.
- If the descaling reminder appears, press OK to run the Descaling function.
- Proofing doesn't operate when the oven is above 125 °F (52 °C).
- If using Proof after cooking, wait for the oven to cool first.
- The Proof mode can only be set as a single stage, not as part of multi-stage cooking.

Editing My Recipes

- The Edit function cannot add or remove cooking stages to a recipe. Only the oven temperature, probe temperature and cook time can be changed.
- 1 Turn the Oven Mode knob to select My Recipes mode.
 - 2 Select the recipe to edit then touch the pencil icon at the bottom left of the screen.
 - 3 Edit the settings for the first cooking stage and touch **Done** to proceed to the next cooking stage, if any.
 - 4 Edit the next cooking stage, touch **Done**, and proceed through all cooking stages in the same way.
 - 5 Once the last cooking stage has been edited, enter a new name for the recipe or keep the previous name. Then touch **Save**.

Deleting My Recipes

- 1 Turn the Oven Mode knob to select My Recipes mode.
- 2 Select the recipe and touch the trash can icon at the bottom left of the screen.
- 3 Touch **Yes**.

Auto Cook

The Auto Cook function provides guidance for cooking foods or dishes that may be unfamiliar. It contains preset programs for cooking many popular food items, with information on recommended preheating, accessories, and rack position for optimal results.

Setting Auto Cook Function

- 1 Turn the Oven Mode knob to select Auto Cook mode.
- 2 Touch a category to filter the options.
- 3 Scroll through or tap the letters to find and select an item.
- 4 Follow the recommendations in the display regarding accessories and rack position.
- 5 Touch **Start**.

Auto Cook Guide

- Preheat oven first for most items.
- Preheat for 5 minutes when broiling.
- If using probe, insert after preheating.

NOTE

- When cooking thin cuts of meat, insert the probe into the thickest part of the meat. If the probe is inserted incorrectly, the oven could turn off too soon. See the Probe section for instructions.

Category	Menu		Accessories/Cookware	Shelf Position	Cooking time in min.		
Meat	Beef	Beef Tenderloin	Rare	Grid on broiler pan	2	30~60	
			Medium rare	Grid on broiler pan	2	35~65	
			Medium	Grid on broiler pan	2	40~70	
			Medium well done	Grid on broiler pan	2	45~75	
			Well done	Grid on broiler pan	2	50~80	
		Pot Roast		Ovenproof pot with cover	2	50~80	
		Roast Beef		Rare	Grid on broiler pan	2	40~70
				Medium rare	Grid on broiler pan	2	45~75
				Medium	Grid on broiler pan	2	50~80
				Medium well done	Grid on broiler pan	2	55~85
				Well done	Grid on broiler pan	2	60~90
		London Broil		Rare	Grid on broiler pan	5	3~10 + 3~10
				Medium rare	Grid on broiler pan	5	5~15 + 3~10
				Medium	Grid on broiler pan	5	5~15 + 5~10
				Medium well done	Grid on broiler pan	5	8~15 + 5~10
				Well done	Grid on broiler pan	5	10~15 + 8~15
		Steak		Rare	Grid on broiler pan	5	3~10 + 3~10
				Medium rare	Grid on broiler pan	5	5~15 + 3~10
				Medium	Grid on broiler pan	5	5~15 + 5~10
				Medium well done	Grid on broiler pan	5	8~15 + 5~10
	Beef Marinade		Grid on broiler pan	3	20~50		
	Meat Loaf		Loaf pan	2	40~60		
	Pork	Pork Butt		Casserole dish	2	60~90	
		Pork Chops		Grid on broiler pan	4	30~50	
		Pork Loin		Grid on broiler pan	2	50~80	
		Pork Tenderloin		Grid on broiler pan	2	20~40	
Lamb	Rack		Grid on broiler pan	2	10~30		
	Bone-in Leg of Lamb		Grid on broiler pan	4	20~40		
Veal	Veal Top Sirloin		Grid on broiler pan	2	80~100		
	Veal Chops		Grid on broiler pan	5	4~15 + 3~10		
	Veal Rolled Roast		Grid on broiler pan	2	50~70		
	Veal Rib Roast		Grid on broiler pan	2	50~80		
	Veal Tenderloin		Grid on broiler pan	2	50~80		
Fish	Fish Fillet		Baking dish	4	10~15		
	Whole		Baking dish	4	15~30		
	Shrimp		Grid on broiler pan	5	5~15		
	Lobster Tails		Grid on broiler pan	4	20~30		
	Steak	Salmon	Rare	Baking dish	4	15~20	
			Medium rare	Baking dish	4	20~25	
Well done			Baking dish	4	15~30		
Poultry	Chicken	Legs & Thighs		Baking dish	4	20~40	
		Wings (Fresh)		Grid on broiler pan	5	8~20	
		Wings (Frozen)		Grid on broiler pan	4	20~40	
		Breasts		Baking dish	4	20~40	
		Cutlet		Casserole dish	4	20~30	
		Whole		Grid on broiler pan	2	60~80	
	Whole Turkey		Grid on broiler pan	2	150~240		
Casserole	Lasagna (Fresh)		Baking dish	3	50~70		

Category	Menu	Accessories/Cookware	Shelf Position	Cooking time in min.	
Pizza	Frozen Thin Crust	Directly on rack	3	10~20	
		On pizza pan	3	10~20	
		On pizza stone	3	10~20	
	Frozen Rising Crust	Directly on rack	3	10~20	
		On pizza pan	3	10~20	
		On pizza stone	3	10~20	
	From Scratch/Homemade	Directly on rack	3	10~20	
		On pizza pan	3	10~20	
		On pizza stone	3	10~20	
Desserts	Brownies		Baking dish	3	30~40
	Cheesecake		Cake pan	3	60~70
	Fruit pie	Whole Pie	Pie pan	3	25~45
		Par Bake Bottom Crust Only	Pie pan	3	20~40
	Fruit tart		Tart pan	3	20~40
	Cakes	Layer Cake	Cake pan	3	25~45
		Angel Food Cake	Cake pan	3	30~40
	Muffins/Cupcakes		Muffin pan	3	20~30
	Puff Pastry		Baking sheet	3	20~40
	Cookies	Single Tray	Baking sheet	3	15~20
		Multiple Tray	Baking sheet	2+4	20~28
	Biscuits/Scones		Baking sheet	3	10~20
	Souffle		Souffle dish	2	60~80
Miscellaneous	Proof		Ovenproof bowl with cover	3	30~40
	Drying/Dehydrating (Fruit or Vegetable)		Baking sheet	3	120 ~ 480
	Slow Roasting		Grid on broiler pan	2	120 ~ 240

Steam Function

Steam cooking uses the moist heat of steam to cook food. This is an ideal cooking method for delicate food items such as seafood, which can lose nutrients when boiled.

The oven provides 3 methods of steam cooking: Gourmet Steam, SousVide and Steam Combi.

CAUTION

- Take care when opening the oven door during or after steam cooking. Hot steam can cause scalding.
- After any steam cooking cycle, the drying function will run automatically. It is normal to hear the steam pump running during the drying function.

Using the Steam Feeder Tank

The steam feeder tank is located over the oven cavity.

- 1 Gently push the front of the steam feeder tank to slide it out.

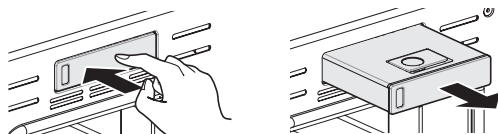

- 2 Remove the tank and place it on a flat surface.
- 3 Remove the tank cover or flip open the fill lid at the front of the tank cover.
- 4 Fill the tank to the max line located at the front of the tank. Use softened, filtered water, if possible. Hard water may clog the steam generator more quickly with scale buildup.

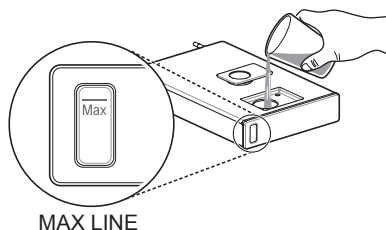

- 5 Assemble the cover or snap closed the fill lid.

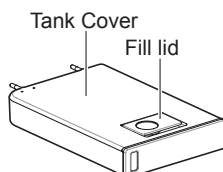

CAUTION

- Make sure the tank cover and fill lid are closed before putting in the oven.
- Use potable water only.
- Do not fill the steam feeder tank with any fluid or mixture other than water.
- Do not fill the tank with hot water.
- Fill the steam feeder tank up to the line indicated on the front.
- Do not tilt the steam feeder tank while it is full.
- Discard any remaining water and clean the steam feeder tank after cooking.
- Use the steam feeder tank only for its intended purpose of providing water for steam cooking.
- Monitor the water level in the tank and refill as needed for steam cooking.

- 6 Carefully insert the tank into the steam feeder slot, making sure to keep the tank level while carrying it. If the tank is not kept level, water will drain out of the tubes in the back.
- 7 Slide the tank into the slot until it clicks into place.

Steam-Combi Mode

The Steam-Combi mode heats food gradually, using both the oven heating elements and moist steam heat. The oven can be programmed to cook at any temperature from 210°F (100 °C) to 550 °F (285 °C). Preset temperature options start at 350 °F (175 °C).

Setting Steam-Combi Mode

- 1 Turn the Oven Mode knob to select Steam Cook mode.
- 2 Touch **Steam-Combi** in the display.
- 3 Select the desired temperature and steam level: Low, Medium, or High.
- 4 If desired, scroll to set the cook time and delayed start time. Touch the arrow key on the right side of the display to see the delayed start time settings.
- 5 Touch **Start**.
- 6 Once cooking is finished, allow oven to cool completely. Then wipe up any water left on the oven interior.

Once Steam-Combi cooking is started, an indicator on the display shows the status of the steam function.

Make sure the steam feeder tank is filled with water before starting the Steam-Combi mode. If the water in the tank runs out during cooking, a chime sounds and a popup appears in the display. The oven continues to cook without steam.

NOTE

- Remember to drain the steam feeder tank after use.
- When the temperature rise in the oven, steam may not be visible.

Changing the Steam Cook Settings

- 1 Touch **Edit** in the display to bring up the Cook Settings screen.
- 2 Adjust the settings as desired.
- 3 Touch **Start**.

To Stop Steam Cooking

- 1 Touch **Stop** in the display, and select Yes, or turn the Mode knob to **OFF** position.

Gourmet Steam

Get great results using preset steam cooking recipes that include recommendations for accessories and rack position.

Setting Gourmet Steam Function

- 1 Turn the Oven Mode knob to select Steam Cook mode.
- 2 Touch **Gourmet Steam** in the display.
- 3 Touch a category to filter the options.
- 4 Scroll through or tap the letters to find and select an item.
- 5 Follow the recommendations in the display regarding accessories and rack position.
- 6 Touch **Start**.
- 7 Once cooking is finished, allow oven to cool completely. Then wipe up any water left on the oven interior.

NOTE

It is normal to hear the sound of boiling water from the steam generator while running the steam functions.

Gourmet Steam Guide

Category	Menu		Accessories/Cookware	Shelf Position	Cooking time in min.	
Breads	White Bread	Homemade	Loaf pan	3	20~50	
		Frozen	Loaf pan	3	20~50	
		Par Baked	Loaf pan	3	20~50	
	Baguette	Homemade	Perforated baguette pan	3	15~35	
		Frozen	Perforated baguette pan	3	15~35	
		Par Baked	Perforated baguette pan	3	15~35	
		Cinnamon Raisin Bread		Loaf pan	3	20~40
		Walnut Bread		Loaf pan or perforated tray	3	40~50
	Whole Grain Bread	Homemade	Loaf pan	3	25~45	
		Frozen	Loaf pan	3	25~45	
		Par baked	Loaf pan	3	25~45	
	Banana Bread	Homemade	Loaf pan	3	25~50	

CAUTION

- Take care when opening the oven door during or after steam cooking. Hot steam can cause scalding.
- After any steam cooking cycle, the drying function will run automatically. It is normal to hear the steam pump running during the drying function.

Sous Vide

Sous vide cooking uses steam to cook foods “low and slow.” Use it to cook meat, fish, seafood, poultry or vegetables. Food must be vacuum packed in pouches.

It is not necessary to preheat the oven when using sous vide.

Refer to the cooking guide for recommended sous vide settings.

Benefits of Sous Vide

The lower temperatures and long cooking times used in sous vide cooking provide many benefits

Healthier

Compared to other cooking methods, sous vide retains most of the original nutrients in food.

Safe and Convenient

The long cooking times used in sous vide cooking allow food to be pasteurized. Because food is vacuum packed before cooking, the unopened pouches can be quickly chilled then easily stored after cooking.

Crisp and Moist Results

The fine temperature control of sous vide cooking is an excellent way to achieve the perfect texture when cooking meat and poultry. The low temperatures used retain more of the moisture in food than conventional cooking methods. After cooking, a final sear in a frying pan adds the perfect crisp finish.

Setting Sous Vide Mode

- 1 Fill the tank with water up to the max line located at the front of the tank
- 2 Place the heavy duty rack in position **3** and place the sealed food bag on it.
- 3 Turn the Oven Mode knob to select Steam Cook mode.
- 4 Touch **Sous vide** in the display.
- 5 Select the desired temperature.
- 6 If desired, scroll to set the cook time and delayed start time. Touch the arrow key on the right side of the display to see the delayed start time settings.
- 7 Touch **Start**.
- 8 Once cooking is finished, allow the oven to cool completely. Then wipe up any water left on the oven interior

Changing the Sous Vide Settings

- 1 Touch **Edit** in the display to bring up the cook settings screen.
- 2 Adjust the settings as desired.
- 3 Touch **Start**.

To Stop Cooking

- 1 Touch **Stop** in the display, and select Yes, or turn the Mode knob to **OFF** position.

NOTE

As the temperature in the oven rises, steam may not be visible.

Sous Vide Cooking Guide

The size, weight, thickness, starting temperature, and your personal preferences will affect operating times. This guide is only for reference. Adjust cook time according to your preference.

		Temp.	Time		
			Min	Target	Max
Beef steak (Medium rare)	1" thick, 400-500 g	135 °F	-	2.5 hr	3 hr
Chicken breast	120-150 g	149 °F	-	2.5 hr	3 hr
Salmon	1" thick, 200 g	140 °F	-	2 hr	2.5 hr
Asparagus	80 g / 6 ea, 160 g / 12 ea	185 °F	20 min.	30 min.	45 min.

Cook 30 mins. or 1 hour more if you use meats thicker than 1".

If you use larger meats, cut to match the recommended weight. Be careful not to put pieces of meat too close together.

SMART FUNCTIONS

LG ThinQ Application

This feature is only available on models with Wi-Fi.

The **LG ThinQ** application allows you to communicate with the appliance using a smartphone.

LG ThinQ Application Features

- **SpeedClean™**
 - Allows you to set SpeedClean™ alerts, read the instruction guide, and simulate and compare energy consumption when using SpeedClean™ versus self clean cycles.
 - This feature is only available for lower oven.
- **Smart Diagnosis™**
 - This function provides useful information for diagnosing and solving issues with the appliance based on the pattern of use.
- **Settings**
 - Allows the user to change oven settings, including the hour mode, preheat alarm light, beeper volume, temperature units, convection auto conversion, thermostat adjustment and language.
- **Remote Start**
 - Remotely start the preheat mode or turn off the oven. After opening and closing the door, place the mode dial back to Remote Start within 30 seconds.
 - This feature is only available for lower oven.
- **Monitoring**
 - This function helps you check the current status, remaining time, cook settings and end time in one place.
- **Product Notifications**
 - Turn on the Push Alerts to receive appliance status notifications. The notifications are triggered even if the **LG ThinQ** application is not open.
- **Timer**
 - You can set the timer from the application.
 - This feature is only available for lower oven.

NOTE

- If you change your wireless router, Internet service provider, or password, delete the registered appliance from the **LG ThinQ** application and register it again.
- This information is current at the time of publication. The application is subject to change for product improvement purposes without notice to users.

Installing LG ThinQ Application and Connecting an LG Appliance

Models with QR Code

Scan the QR code attached to the product using the camera or a QR code reader application on your smartphone.



Models without QR Code

- 1 Search for and install the **LG ThinQ** application from the Google Play Store or Apple App Store on a smartphone.
- 2 Run the **LG ThinQ** application and sign in with your existing account or create an LG account to sign in.
- 3 Touch the add (+) button on the **LG ThinQ** application to connect your LG appliance. Follow the instructions in the application to complete the process.

NOTE

- To verify the Wi-Fi connection, check that the Wi-Fi indicator on the control panel is lit.
- The appliance supports 2.4 GHz Wi-Fi networks only. To check your network frequency, contact your Internet service provider or refer to your wireless router manual.
- **LG ThinQ** is not responsible for any network connection problems or any faults, malfunctions, or errors caused by network connection.
- The surrounding wireless environment can make the wireless network service run slowly.
- If the distance between the appliance and the wireless router is too far, the signal becomes weak. It may take a long time to connect or fail to install the application.
- If the appliance is having trouble connecting to the Wi-Fi network, it may be too far from the router. Purchase a Wi-Fi repeater (range extender) to improve the Wi-Fi signal strength.
- The network connection may not work properly depending on the Internet service provider.
- The Wi-Fi may not connect or the connection may be interrupted because of the home network environment.

NOTE

- If the appliance cannot be connected due to problems with the wireless signal transmission, unplug the appliance and wait about a minute before trying again.
- If the firewall on your wireless router is enabled, disable the firewall or add an exception to it.
- The wireless network name (SSID) should be a combination of English letters and numbers. (Do not use special characters.)
- Smartphone user interface (UI) may vary depending on the mobile operating system (OS) and the manufacturer.
- If the security protocol of the router is set to **WEP**, network setup may fail. Change the security protocol (**WPA2** is recommended), and connect the product again.

Remote Start

If the appliance is registered on a home Wi-Fi network, the preheating function of the oven can be started or stopped using the LG ThinQ smart phone app.

Preparing the Oven for a Remote Start

- 1 Open the oven door to make sure the oven is empty and ready for preheating. Do not place food in the oven. Close the oven door. Remote Start can only be set when the oven door is closed.
- 2 Touch **SETTINGS**, located at the center bottom of the display. Touch Remote Start on the first Settings screen, and then select On. Follow the instructions on the popup that opens in the display
- 3 Follow the instructions in the LG ThinQ smartphone app for using the Remote Start function.

NOTE

- Remote Start is disconnected in the following situations:
 - Remote Start is never set up in the smart phone app.
 - The Remote Start status is “ready”.
 - Remote Start experiences a problem during operation.
- The Wi-Fi icon on the display shows the status of the appliance's network connection. If the Wi-Fi icon is not lit, use the smart phone app to select the Wi-Fi network or register the product again.
- A faulty Wi-Fi connection could delay the Remote Start function.
- Disconnect the probe if attached.

Smart Diagnosis™ Feature

Use this feature to help you diagnose and solve problems with your appliance. NFC or Wi-Fi equipped models can also transmit data to a smartphone using the **LG ThinQ** application.



NOTE

- For reasons not attributable to **LGE's** negligence, the service may not operate due to external factors such as, but not limited to, Wi-Fi unavailability, Wi-Fi disconnection, local app store policy, or app unavailability.
- The feature may be subject to change without prior notice and may have a different form depending on where you are located.

Using LG ThinQ to Diagnose Issues

If you experience a problem with your Wi-Fi equipped appliance, it can transmit troubleshooting data to a smartphone using the **LG ThinQ** application.

- Launch the **LG ThinQ** application and select the **Smart Diagnosis** feature in the menu. Follow the instructions provided in the **LG ThinQ** application.

Using Audible Diagnosis to Diagnose Issues

Follow the instructions below to use the audible diagnosis method.

- Launch the **LG ThinQ** application and select the **Smart Diagnosis** feature in the menu. Follow the instructions for audible diagnosis provided in the **LG ThinQ** application.

- 1 Touch **SETTINGS**, located at the center bottom of the main display screen. Swipe to the third settings screen and select **Smart Diagnosis™**. Follow the instructions in the display.

NOTE

Do not touch any other buttons or icons on the display screen.

- 2 Touch **Start**.
- 3 Keep the phone in place until the tone transmission has finished. The display will count down the time. Once the countdown is over and the tones have stopped, the diagnosis will be displayed in the application.
- 4 Once the tones have stopped, resume your conversation with the call agent, who will assist you in using the information transmitted.

NOTE

- For best results, do not move the phone while the tones are being transmitted.

Open Source Software Notice Information

To obtain the source code that is contained in this product, under GPL, LGPL, MPL, and other open source licenses that have the obligation to disclose source code, and to access all referred license terms, copyright notices and other relevant documents, please visit <https://opensource.lge.com>.

SIGNATURE KITCHEN SUITE will also provide open source code to you on CD-ROM for a charge covering the cost of performing such distribution (such as the cost of media, shipping, and handling) upon email request to opensource@lge.com. This offer is valid to anyone in receipt of this information for a period of three years after our last shipment of this product.

Wireless LAN Module Specifications

Frequency Range	2412 MHz – 2462 MHz
Output Power (Max)	< 30 dBm

FCC Statement

This equipment has been tested and found to comply with the limits for a Class B digital device, pursuant to part 15 of the FCC Rules for transmitter module and part 18 of the FCC Rules for this equipment. These limits are designed to provide reasonable protection against harmful interference in a residential installation. This equipment generates, uses and can radiate radio frequency energy and, if not installed and used in accordance with the instructions, may cause harmful interference to radio communications. However, there is no guarantee that interference will not occur in a particular installation. If this equipment does cause harmful interference to radio or television reception, which can be determined by turning the equipment off and on, the user is encouraged to try to correct the interference by one or more of the following measures:

- Reorient or relocate the receiving antenna.
- Increase the separation between the equipment and the receiver.
- Connect the equipment into an outlet on a circuit different from that to which the receiver is connected.
- Consult the dealer or an experienced radio/TV technician for help.

This device (transmitter module contained in this product) complies with part 15 of the FCC Rules. Operation is subject to the following two conditions:

- (1) This device may not cause harmful interference and
- (2) This device must accept any interference received, including interference that may cause undesired operation.

Any changes or modifications in construction of this device which are not expressly approved by the party responsible for compliance could void the user's authority to operate the equipment.

FCC RF Radiation Exposure Statement

This equipment complies with FCC radiation exposure limits set forth for an uncontrolled environment. This transmitter must not be co-located or operating in conjunction with any other antenna or transmitter.

This equipment should be installed and operated with a minimum distance of 20 cm (7.8 inches) between the antenna and your body. Users must follow the specific operating instructions for satisfying RF exposure compliance.

MAINTENANCE

Caring for the Upper Oven

To make sure the microwave oven looks good and works well for a long time, maintain it properly. For proper care, follow these instructions carefully.

Cleaning the Interior

Wash often with warm, sudsy water and a sponge or soft cloth. Use only mild, nonabrasive soaps or a mild detergent. **Keep the areas clean where the door and oven frame touch when closed.**

Wipe well with a clean cloth. Over time, stains can occur on the surfaces as the result of food particles spattering during cooking. This is normal.

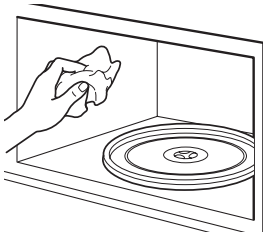

For stubborn soil, boil a cup of water in the oven for 2 to 3 minutes. Steam will soften the soil. To get rid of odors inside the oven, boil a cup of water with some lemon juice or vinegar in it.

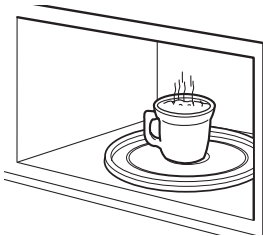

CAUTION

- Do not use oven cleaners, harsh chemical cleaners, bleach, vinegar, steel scouring pads, or abrasive pads or cleansers to clean the oven, as they can permanently damage the oven surface.
- Do not clean the gasket.

Cleaning the Exterior

Use a soft cloth sprayed with glass cleaner.

Apply the glass cleaner to the soft cloth; do not spray directly on the oven.

NOTE

Abrasive cleansers, steel wool pads, gritty wash cloths, some paper towels, etc., can damage the control panel and the interior and exterior oven surfaces.

To clean the glass tray and rotating ring, wash in mild, sudsy water.

For heavily soiled areas use a mild cleanser and scouring sponge.

The glass tray and rotating ring are dishwasher safe.

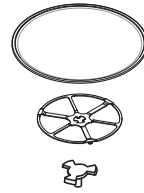

Glass Tray

Rotating Ring

Shaft

Caring for the Lower Oven

Self Clean

The Self Clean cycle uses extremely hot temperatures to clean the oven cavity. While running the Self Clean cycle, you may notice smoking or an odor. This is normal, especially if the oven is heavily soiled.

During the Self Clean cycle, the kitchen should be well-ventilated to minimize the odors from cleaning.

CAUTION

- DO NOT leave small children unattended near the appliance. During the Self Clean cycle, the outside of the oven can become very hot to touch.
- If you have pet birds, move them to another well-ventilated room. The health of some birds is extremely sensitive to the fumes given off during the Self Clean cycle of any oven.
- DO NOT line the oven walls, racks, bottom or any other part of the oven with aluminum foil or any other material. Doing so will destroy heat distribution, produce poor baking results and cause permanent damage to the oven interior (aluminum foil will melt to the interior surface of the oven).
- DO NOT force the door open. This can damage the automatic door locking system. Use care when opening the oven door after the Self Clean cycle. Stand to the side of the oven when opening the door to allow hot air or steam to escape. The oven may still be VERY HOT.

Before Starting Self Clean

- Remove the water tank, oven racks, broiler pan, broiler grid, all cookware, aluminum foil or any other material from the oven. Leaving items in the oven will cause permanent damage to the oven interior.
- If you don't remove the water tank from the oven, a beep sounds, and the Self Clean cycle does not start.

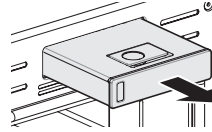

- The kitchen should be well ventilated to minimize the odors from cleaning.
- Wipe any heavy spillovers on the bottom of the oven.
- Make sure that the oven light bulb cover is in place and the oven light is off.
- The oven light cannot be turned on during a Self Clean cycle. The oven light cannot be turned on until the oven temperature has cooled below 500 °F (260 °C) after a Self Clean cycle is complete.

NOTE

- Remove oven racks and accessories before starting the Self Clean cycle.
- If oven racks are left in the oven cavity during the Self Clean cycle, they will discolor and become difficult to slide in and out.
- Clean the frame of the oven and door with hot soapy water. Rinse well.
- Do not clean the gasket. The fiberglass material of the oven door gasket cannot withstand abrasion.
- It is essential for the gasket to remain intact. If you notice it becoming worn or frayed, replace it.
- It is normal for the fan to operate during the Self Clean cycle.

Setting Self Clean

The Self-Clean function has cycle times of 3, 4, or 5 hours.

Self Clean Soil Guide

Soil Level	Cycle Setting
Lightly soiled oven cavity	3 Hour Self Clean
Moderately soiled oven cavity	4 Hour Self Clean
Heavily soiled oven cavity	5 Hour Self Clean

- 1 Remove all racks and accessories from the oven.
- 2 Turn the Oven Mode knob to select the Clean mode, and Touch **Self clean**. The oven defaults to the recommended four-hour self clean for a moderately soiled oven.
- 3 Select the desired cycle time.
- 4 If desired, scroll to set a delayed start time or touch the number pad icon  to enter the start time directly.
- 5 Touch Start. The remaining time or the delayed start time appears in the display.
- 6 Once the self-clean cycle is set, the oven door locks automatically and the lock icon displays.
You will not be able to open the oven door until the oven has cooled. The lock releases automatically when the oven has cooled.



CAUTION

DO NOT force the oven door open when the lock icon is displayed. The oven door will remain locked until the oven temperature has cooled. Forcing the door open will damage the door.

NOTE

It may become necessary to cancel or interrupt a self clean cycle due to excessive smoke or fire in the oven. To cancel the Self Clean function, touch **Stop** in the display or turn the Oven Mode knob to **OFF** position.

During Self Clean

- The self clean cycle uses extremely hot temperatures to clean the oven cavity. While running the Self Clean cycle, you may notice smoking or an odor. This is normal, especially if the oven is heavily soiled.
- As the oven heats, you may hear sounds of metal parts expanding and contracting. This is normal and will not damage the oven.
- Do not force the oven door open when the lock  is displayed. The oven door remains locked until the oven temperature has cooled. Forcing the door open will damage the door.

NOTE

- The Self Clean cycle cannot be started if the Lockout feature is active.
- Once the Self Clean cycle is set, the oven door will lock automatically. You will not be able to open the oven door until the oven is cooled. The lock will release automatically.
- Once the door has been locked, the lock  indicator light stops flashing and remains on. Allow about 15 seconds for the oven door lock to activate.
- If the clock is set for a 12 hour display (default) the Delayed Self Clean can never be set to start more than 12 hours in advance.
- After the oven is turned off, the cooling fan keeps operating until the oven has cooled down.

After the Self Clean Cycle

- The oven door will remain locked until the oven temperature has cooled.
- You may notice some white ash in the oven. Wipe it off with a damp cloth or a non-scratch scrub pad after the oven cools. If the oven is not clean after one clean cycle, repeat the cycle.
- If oven racks were left in the oven and do not slide smoothly after a clean cycle, wipe racks and rack supports with a small amount of vegetable oil to make them glide more easily.
- Fine lines may appear in the porcelain because it went through heating and cooling. This is normal and will not affect performance.

Steam Feeder Tank

The steam feeder tank is used during the steam cooking functions. Use filtered, softened water if possible.

NOTE

- After using the steam function, the steam feeder tank should be drained. To avoid bacteria or odors, clean and dry the steam feeder tank after every use.
- Do not clean in a dishwasher.
- If the steam feeder tank does not slide in as smoothly as it should, clean the bottom of the tank.



Hard Water Scale

If hard water is used in the steam feeder tank, the steam generator may become clogged with hard water scale. In areas with hard water, run the Descaling function frequently or use softened water.

Cleaning Scale on Oven Bottom

To remove mineral deposits that remain on the oven bottom after using the steam mode, use a cloth or sponge soaked in vinegar or a weak citric acid solution. For more stubborn or extensive scaling, use the Descaling function.

Descaling

Use this function to remove the white deposits that form after the steam generator is used for a long period.

The Descaling function runs for 1 hour 43 minutes. Water will come out of the steam generator while it is being cleaned.

For instructions on removing and filling the steam feeder tank, see "Using the Steam Feeder Tank."

Setting Descaling

- 1 Fill the steam feeder tank with a 20:1 mixture of water and citric acid. For example, use 4 tsp of citric acid in 4 1/4 cups water (20 g citric acid in 1000 ml water).
- 2 Insert the steam feeder tank into the slot over the oven cavity and push it in until it clicks into place.
- 3 Turn the Oven Mode knob to select Clean mode. Touch Steam Maintenance and Descaling in that order.

- 4 After 1 hour 43 minutes of descaling, a popup will appear in the display. Following the instructions, drain the tank and fill it with clean water.

- 5 Insert the tank and start the Rinsing function.

- 6 Once the Rinsing function is complete, dry the inside of the oven with a soft cloth. Leave the oven door open and allow the oven to dry completely.

NOTE

- The Rinsing function must be completed even if the Descaling function is canceled.
- If water remains on the oven bottom after descaling, it can leave a residue after the oven is used. To remove the residue, see the instructions under "Cleaning Scale on Oven Bottom."
- After running the Descaling function, clean the steam feeder tank.

Drying

The Drying function removes residual water inside the steam generator. The function takes a little over 1 minute and runs automatically after any steam cooking cycle. The Drying function can also be started manually, if needed.

Setting Drying

- 1 Make sure that the steam feeder tank is empty.
- 2 Turn the Oven Mode knob to select Clean mode. Touch Steam Maintenance and Drying in that order.
- 3 Touch **Start** to begin Drying. The remaining time appears in the display.

Evaporation

Use the Evaporation function to dry the oven cavity after a steam cooking cycle. Evaporation runs for 12 minutes.

Setting Evaporation

- 1 Turn the Oven Mode knob to select Clean mode. Touch Steam Maintenance and Evaporation in that order.
- 2 Touch **Start** to begin Evaporation. The remaining time appears in the display.

SpeedClean™

SIGNATURE KITCHEN SUITE'S new oven with SpeedClean™ enamel technology provides two cleaning options for the oven interior. The SpeedClean™ feature takes advantage of SIGNATURE KITCHEN SUITE'S new enamel to help lift soils without harsh chemicals, and it runs using ONLY WATER for just 10 minutes in low temperatures to help loosen LIGHT soils before hand-cleaning.

While SpeedClean™ is quick and effective for small and LIGHT soils, the Self Clean feature can be used to remove HEAVY built up soils. The intensity and high heat of the Self Clean cycle may result in smoke which will require the opening up of windows to provide ventilation. Compared to the more intense Self Clean process, your SIGNATURE KITCHEN SUITE oven gives you the option of cleaning with LESS HEAT, LESS TIME, and virtually NO SMOKE OR FUMES.

When needed, your oven still provides the Self Clean option for longer, more thorough cleaning for heavier, built up soils.

BENEFITS OF SpeedClean™

- **Helps loosen light soils** before hand-cleaning
- **SpeedClean™ only uses water**; no chemical cleaners
- Makes for a better Self Clean experience
 - Delays the need for a Self Clean cycle
 - **Minimizes smoke and odors**
 - Can allow shorter Self Clean time

When to use SpeedClean™

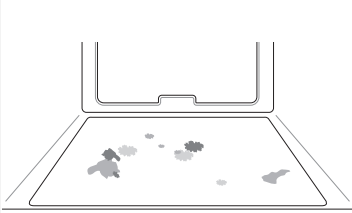
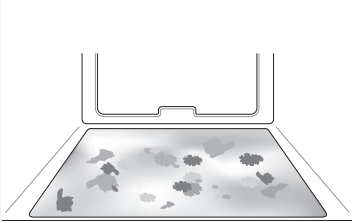
Suggested Cleaning Method	Example of Oven Soiling	Soil Pattern	Types of Soils	Common Food Items That Can Soil Your Oven
SpeedClean™		Small drops or spots	Cheese or other ingredients	Pizza
		Light splatter	Fat/grease	Steaks, broiled
				Fish, broiled
Meat roasted at low temperatures				
Self Clean*		Medium to heavy splatter	Fat/grease	Meat roasted at high temperatures
		Drops or spots	Filling or Sugar based soils	Pies
			Cream or tomato sauce	Casseroles

* The Self Clean cycle can be used for soil that has been built up over time.

Cleaning Tips

- Allow the oven to cool to room temperature before using the SpeedClean™ cycle.
- A plastic spatula can be used as a scraper to scrape off any chunks or debris before and during oven cleaning.
- Using the rough side of a non-scratch scouring pad may help to take off burnt-on stains better than a soft sponge or towel.
- Certain non-scratch scrubbing sponges, such as those made of melamine foam, available at your local stores, can also help improve cleaning.
- The oven should be level to ensure that the bottom surface of the oven cavity is entirely covered by water at the beginning of the SpeedClean™ cycle.
- For best results, use distilled or filtered water. Tap water may leave mineral deposits on the oven bottom.
- Soil baked on through several cooking cycles will be more difficult to remove with the SpeedClean™ cycle.
- Do not open the oven door during the SpeedClean™ cycle. Water will not get hot enough if the door is opened during the cycle.
- For hard to reach areas such as the back surface of the oven, it is better to use the Self Clean cycle.

SpeedClean™ Instruction Guide

- 1 Remove oven racks and accessories from the oven.
- 2 Scrape off and remove any burnt-on debris with a plastic scraper.

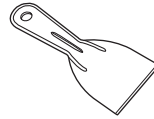

Suggested plastic scrapers:

- Hard plastic spatula
- Plastic pan scraper
- Plastic paint scraper
- Old credit card

- 3 If cleaning the oven, fill the steam feeder tank to the maximum fill line with water.
- 4 Turn the Oven Mode knob to select the Clean mode. Then select SpeedClean in the display.
- 5 Touch Start. The remaining time appears in the display.

CAUTION

- Some surfaces may be hot after the SpeedClean™ cycle. Wear rubber gloves while cleaning to prevent burns.
- During the SpeedClean™ cycle, the oven bottom becomes hot enough to cause burns. Wait until the cycle is over before wiping the inside surface of the oven. Failure to do so may result in burns.
- Avoid leaning or resting on the oven door glass while cleaning the oven cavity.

- 6 A tone will sound at the end of the 10-minute cycle. Turn the Oven Mode knob to the OFF position to clear the display and end the tone.
- 7 After the cleaning cycle and during hand-cleaning, enough water should remain on the oven bottom to completely submerge all soils. Add water if necessary. Place a towel on the floor in front of the oven to capture any water that may spill out during hand-cleaning.

- 8** Clean the oven cavity immediately after the SpeedClean™ cycle by scrubbing with a wet, non-scratch scouring sponge or pad. (The scouring side will not scratch the finish.) Some water may spill into the bottom vents while cleaning, but it will be captured in a pan under the oven cavity and will not hurt the burner.

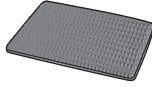
**NOTE**

DO NOT use any steel scouring pads, abrasive pads or cleaners as these materials can permanently damage the oven surface.

- 9** Once the oven cavity is cleaned, wipe any excess water with a clean dry towel. Replace racks and any other accessories.
- 10** If some light soils remain, repeat the above steps, making sure to thoroughly soak the soiled areas. If stubborn soils remain after multiple SpeedClean™ cycles, run the Self Clean cycle. Be sure that the oven cavity is empty of oven racks and other accessories, and that the oven cavity surface is dry before running the Self Clean cycle. Consult the Self Clean section for further details.

NOTE

- The cavity gasket may be wet when the SpeedClean™ cycle finishes. This is normal. Do not clean the gasket.
- If mineral deposits remain on the oven bottom after cleaning, use a cloth or sponge soaked in vinegar to remove them.
- Using commercial oven cleaners or bleach to clean the oven is not recommended. Instead, use a mild liquid cleanser with a PH value below 12.7 to avoid discoloring the enamel.

Cleaning the Exterior

Painted Surfaces

For general cleaning, use a cloth with hot soapy water. For more difficult soils and built-up grease, apply a liquid detergent directly onto the soil. Leave it on for 30 to 60 minutes. Rinse with a damp cloth and dry. Do not use abrasive cleaners.

Stainless Steel Surfaces

To avoid scratches, do not use steel wool pads.

- 1** Place a small amount of stainless steel appliance cleaner or polish on a damp cloth or paper towel.
- 2** Clean a small area, rubbing with the grain of the stainless steel if applicable.
- 3** Dry and buff with a clean, dry paper towel or soft cloth.
- 4** Repeat as necessary.

NOTE

- Do not use a steel wool pad. it will scratch the surface.
- To clean the stainless steel surface, use warm sudsy water or a stainless steel cleaner or polish.
- Always wipe in the direction of the metal surface finish.
- Stainless steel appliance cleaner or polish can be purchased online or from most retailers of appliances or home goods.

Oven Door

- Use soapy water to thoroughly clean the oven door. Rinse well. DO NOT immerse the door in water.
- You may use a glass cleaner on the outside glass of the oven door. DO NOT spray water or glass cleaner on the door vents.
- DO NOT use oven cleaners, cleaning powders, or harsh abrasive cleaning materials on the outside of the oven door.
- DO NOT clean the oven door gasket. The oven door gasket is made of a woven material that is essential for a good seal. Care should be taken not to rub, damage, or remove this gasket.



CAUTION

Do not use harsh cleaners or harsh abrasive cleaning materials on the outside of the oven door. Doing so can cause damage.

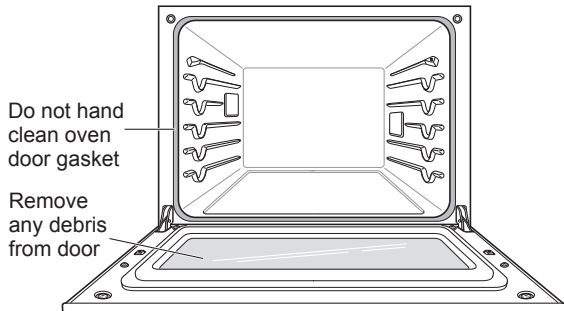

Broiler Pan and Grid

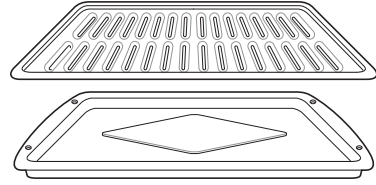

- Do not store a soiled broiler pan or grid anywhere in the oven.
- Do not clean the broiler pan or grid in the self cleaning mode.
- Remove the grid from the pan. Carefully pour out the grease from the pan into a proper container.
- Wash and rinse the broiler pan and grid in hot water with a soap-filled or plastic scouring pad.
- If food has burned on, sprinkle the grid with cleaner while hot and cover with wet paper towels or a dishcloth. Soaking the pan will remove burned-on foods.
- Both the broiler pan and grid may be cleaned with a commercial oven cleaner or in the dishwasher.

Oven Racks

Remove the oven racks before operating the Self Clean cycle. Leaving the racks in place could cause discoloration.

If the racks are cleaned in the Self Clean cycle, their color will turn slightly blue and the finish will be dull. After the Self Clean cycle is complete and the oven has cooled, rub the sides of the racks with wax paper or a cloth containing a small amount of oil. This will make the racks glide more easily into the rack tracks.

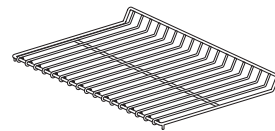

Oven Cavity

DO NOT use oven cleaners.

NEVER wipe a warm or hot porcelain surface with a damp sponge; it may cause chipping or crazing (tiny hairlike cracks). Food spills should be cleaned when the oven cools. At high temperature, foods react with porcelain and a permanent dull spot can result. When cleaning a spot, use only non-abrasive cleaners or scrubbers.

Changing the Oven Light

The oven light is a standard 25-watt halogen bulb.

WARNING

- Make sure that the oven and bulb are cool.
- Disconnect the electrical power to the oven at the main fuse or circuit breaker panel. Failure to do so can result in severe personal injury, death, or electrical shock.
- Wear gloves while changing the oven light. Glass fragments from broken bulbs can cause risk of injury.
- Gently twist the screwdriver blade while changing the oven light. If you apply force, the glass or oven may crack.

To replace lamps located on the side wall:

- **Make sure oven and bulb are cool.**

- 1 Unplug oven or disconnect power.
- 2 Remove oven racks.
- 3 Slide a flat blade screwdriver between the housing and the glass light cover.
- 4 Support the glass light cover with two fingers to prevent the cover from falling to the bottom of the oven.

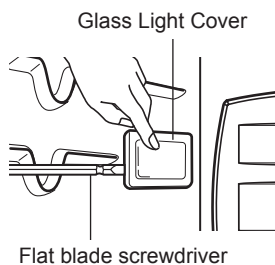

- 5 Gently twist the screwdriver blade to loosen the glass light cover and remove it.

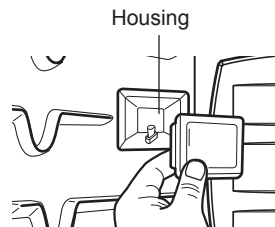

- 6 Remove bulb from socket.
- 7 Replace the bulb, and snap the light cover back into place.
- 8 Plug in oven or reconnect power.

Removing and Replacing the Oven Door

CAUTION

- The door is very heavy. Be careful when removing and lifting the door.
- DO NOT lift the door by the handle. The handle is not designed to support the weight of the door and could break.
- DO NOT hit the glass with pots, pans, or any other object.
- Scratching, hitting, jarring or stressing the glass may weaken its structure, causing an increased risk of breakage at a later time.

Removing the Oven Door

- 1 Fully open the door.
- 2 Unlock the hinge on both sides, rotating them as far toward the open door frame as they will go.

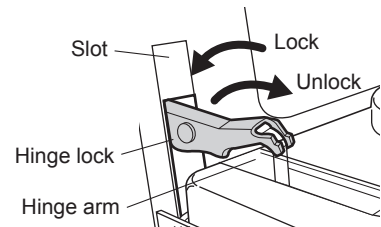

- 3 Firmly grasp both sides of the door at the top.
- 4 Close the door to the removal position (approximately 5 degrees) which is halfway between the broil stop position and fully closed. If the position is correct, the hinge cams will move freely.

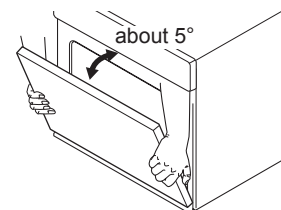

Removal Position

- 5 Lift door up and out until the hinge cams are clear of the slots.

Replacing the Door

- 1 Firmly grasp both sides of the door at the top.
- 2 With the door at the same angle as the removal position, seat the indentation of the hinge cams into the bottom edge of the hinge slots. The notch in the hinge cams must be fully seated into the bottom edge of the slots.

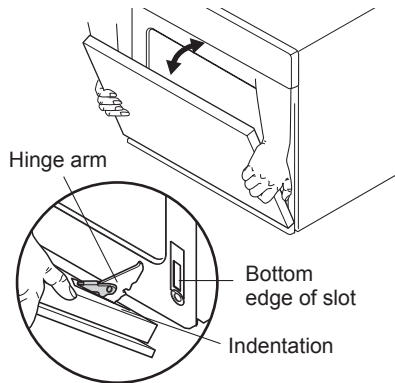

- 3 Open the door fully. If the door will not open fully, the indentation is not seated correctly in the bottom edge of the slots.
- 4 Lock the hinges on either side of the door, rotating them back toward the slots in the oven frame until they lock.

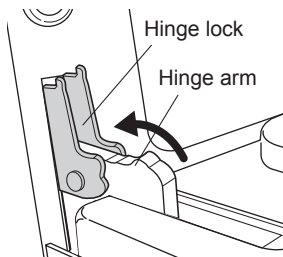

Push hinge locks up to lock

- 5 Close the oven door.

Door Care Instructions

Most oven doors contain glass that can break.

CAUTION

- Do not close the oven door until all the oven racks are fully in place.
- Do not hit the glass with pots, pans, or any other object.
- Scratching, hitting, jarring, or stressing the glass may weaken its structure causing an increased risk of breakage at a later time.

TROUBLESHOOTING

FAQs

My new oven doesn't cook like my old one. Is there something wrong with the temperature settings?

No, Your oven has been factory tested and calibrated. For the first few uses, follow your recipe times and temperatures carefully. If you still think your new oven is too hot or too cold, you can adjust the oven temperature yourself to meet your specific cooking needs. Refer to the Temperature Adjustment section, page 18, for easy instructions on how to adjust your thermostat.

Can I use a rack in my upper oven to reheat or cook on two levels at once?

Only use the rack that is supplied with your upper oven. Use of any other rack can result in poor cooking performance and/or arcing and may damage your oven.

Will the upper oven be damaged if it operates empty?

Yes. Never operate the oven empty or without the glass tray.

Does microwave energy pass through the viewing screen in the door?

No. The metal screen bounces the energy back to the oven cavity. The holes (or ports) allow only light to pass through. They do not let microwave energy pass through.

Why do I see light reflection around the outer case?

This light is from the upper oven light which is located between the oven cavity and the outer wall of the oven.

What are the various sounds I hear when the upper oven is operating?

The clicking sound is caused by a mechanical switch turning the microwave oven's magnetron ON and OFF.

The heavy hum and clunk is from the change in power the magnetron draws as it is turned ON and OFF by a mechanical switch. The change in blower speed is from the change in line voltage caused by the magnetron being turned ON and OFF.

Can my upper oven be damaged if food is cooked for too long?

Like any other cooking appliance, it is possible to overcook food to the point that the food creates smoke and even possibly fire, and damage to the inside of the oven. It is always best to be near the oven while you are cooking.

Why is a standing time recommended after microwave cooking time is over?

Standing time allows foods to continue cooking evenly for a few minutes after the actual microwave oven cooking cycle. The amount of standing time depends upon the density of the foods.

Why is additional time required for cooking food stored in the refrigerator?

As in conventional cooking, the initial temperature of food affects total cooking time. You need more time to cook food taken out of a refrigerator than for food at room temperature.

Can I use either metal or aluminum pans in my upper oven?

Usable metal includes aluminum foil for shielding (use small, flat pieces), and shallow foil trays (if tray is $\frac{3}{4}$ inch deep and filled with food to absorb microwave energy). Never allow metal to touch walls or door.

Sometimes the door of my upper oven appears wavy. Is this normal?

This appearance is normal and does not affect the operation of your oven.

The glass tray does not move.

The glass tray is not correctly in place. It should be correct-side up and sitting firmly on the center hub. The support is not operating correctly. Remove the glass tray and restart the oven. Cooking without the glass tray can give you poor results.

Why does the dish become hot when I microwave food in it? I thought that this should not happen.

As the food becomes hot it will conduct the heat to the dish. Use hot pads to remove food after cooking.

What does standing time mean?

Standing time means that food should be taken out of the oven and covered for additional time after cooking. This process allows the cooking to finish, saves energy, and frees the oven for other purposes.

Can I pop popcorn in my upper oven? How do I get the best results?

Yes. Pop packaged microwave popcorn following manufacturer's guidelines or use the preprogrammed Popcorn key.

Do not use regular paper bags. Use the listening test by stopping the oven as soon as the popping slows to a pop every one or two seconds. Do not try to repop unpopped kernels. You can also use special microwave poppers. When using a popper, be sure to follow manufacturer's directions. Do not pop popcorn in glass cookware.

Why does steam come out of the air exhaust vent?

Steam is normally produced during cooking. The upper oven has been designed to vent steam out of the top vent.

The Lower oven doesn't cook like my old one. Is there something wrong with the temperature settings?

No, your oven has been factory tested and calibrated. For the first few uses, follow your recipe times and temperatures carefully. If you still think your new oven is too hot or too cold, you can adjust the oven temperature yourself to meet your specific cooking needs. Refer to the Oven Temperature Adjustment section in this manual for easy instructions on how to adjust your thermostat.

Is it normal to hear a clicking noise coming from the back of the lower oven when I am using it?

Your new oven is designed to maintain a tighter control over your oven's temperature. You may hear your oven's heating elements click on and off more frequently on your new oven. This is NORMAL.

Why is the time flashing?

This means that the product has just been plugged in, or that it has experienced a power interruption. To clear the flashing time, touch any button and reset the clock if needed.

During convection cooking the fan stops when I open the door. Is that normal?

Yes, this is normal. When the door is opened, the convection fan will stop until the door is closed.

Can I use aluminum foil to catch drippings in the lower oven cavity?

Never use aluminum foil to line the bottom or sides of the oven. The foil will melt and stick to the bottom surface of the oven and will not be removable. Use a sheet pan placed on a lower oven rack to catch drippings instead. (If foil has already melted onto the bottom of the oven, it will not interfere with the oven's performance.)

Can I use aluminum foil on the racks?

Do not cover racks with aluminum foil. Covering entire racks with foil restricts air flow, leading to poor cooking results. Use a sheet pan lined with foil under fruit pies or other acidic or sugary foods to prevent spillovers from damaging the oven finish.



CAUTION

Foil may be used to wrap food in the lower oven, but do not allow the foil to come into contact with the exposed heating/broiling elements in the oven. The foil could melt or ignite, causing smoke, fire, or injury.

Can I leave my racks in the oven when running a Self Clean cycle?

No. Although it will not damage the racks, it will discolor them and may make them hard to slide in and out during use. Remove all items from the oven before starting a Self Clean cycle.

What should I do if my racks are sticky and have become hard to slide in and out?

Over time, the racks may become hard to slide in and out. Apply a small amount of olive oil to the ends of the racks. This will work as a lubricant for easier gliding.

Should I broil with the door open or closed?

Your oven isn't designed for open door broiling. If you broil with the oven door open, it can damage the oven knobs and display.

Why aren't the function buttons working?

Make sure that the oven is not in Lockout mode. The lock  will show in the display if Lockout is activated. To deactivate Lockout, tap the display to see the unlock popup. Press **UNLOCK** for 3 seconds to cancel the lockout function. The lock icon will disappear at the upper right in the display.

My oven is still dirty after running the SpeedClean™ cycle. What else should I do?

The SpeedClean™ cycle only helps to loosen light soils in your oven to assist in hand-cleaning of your oven. It does not automatically remove all soils after the cycle. Some scrubbing of your oven is required after running the SpeedClean™ cycle.

I tried scrubbing my oven after running SpeedClean™, but some soils still remain. What can I do?

The SpeedClean™ feature works best when the soils are fully soaked and submerged in water before running the cycle and during hand-cleaning. If soils are not sufficiently soaked in water, it can negatively affect the cleaning performance. Repeat the SpeedClean™ process using sufficient water. Sugar-based and certain greasy soils are especially hard to clean. If some stubborn soils remain, use the Self Clean feature to thoroughly clean your oven.

Soil on the oven walls is not coming off. How can I clean the oven walls?

Soils on the side and rear walls of your oven may be more difficult to fully soak with water. Try repeating the SpeedClean™ process with more than the ¼ cup (2 oz or 60 ml).

Will SpeedClean™ get all of the soils and stains out completely?

It depends on the soil type. Sugar-based and certain grease stains are especially hard to clean. Also, if stains are not sufficiently soaked in water, this can negatively affect cleaning performance. If stubborn or built-up stains remain, use the Self Clean feature. Refer to the Self Clean section of your owner's manual.

Are there any tricks to getting some of the stubborn soils out?

Scraping the soils with a plastic scraper before and during hand-cleaning is recommended. Fully saturating soils with water is also recommended. However, certain types of soils are harder to clean than others. For these stubborn soils, the Self Clean cycle is recommended. Consult the Self Clean section of your owner's manual for details.

Is it safe for my convection fan, broil burner or heater element to get wet during SpeedClean™?

Yes. The convection fan, broiler burner or heater element may get a little wet during cleaning. However, direct spray onto the broil burner and heater elements is not necessary because these are self-cleaning during regular use.

I see smoke coming out of my oven's vents during SpeedClean™. Is this normal?

This is normal. This is not smoke. It is actually water vapor (steam) from the water in the oven cavity. As the oven heats briefly during SpeedClean™, the water in the cavity evaporates and escapes through the oven vents.

How often should I use SpeedClean™?

SpeedClean™ can be performed as often as you wish. SpeedClean™ works best when your oven is LIGHTLY soiled from such things as LIGHT grease splatter and small drops of cheese. Please refer to the SpeedClean™ section in your owner's manual for more information.

What is required for SpeedClean™?

A plastic scraper, a non-scratch scrubbing pad and a towel. You should not use abrasive scrubbers such as heavy-duty scouring pads or steel wool.

Before Calling for Service

Before you call for service, review this list. It may save you time and expense. The list includes common occurrences that are not the result of defective workmanship or materials in this appliance.

Symptoms	Possible Causes / Solutions							
Oven control beeps and displays any F code error	<ul style="list-style-type: none"> • Electronic control has detected a fault condition. Touch any button and turn any knob once to clear the display and stop the beeping. Reprogram oven. If fault reoccurs, record fault number. Clear the display and stop the beeping. Then contact a qualified service technician. <table border="1" data-bbox="902 311 1263 494"> <thead> <tr> <th data-bbox="902 311 1005 349">CODE</th> <th data-bbox="1005 311 1263 349">CAUSE</th> </tr> </thead> <tbody> <tr> <td data-bbox="902 349 1005 421">F-9</td> <td data-bbox="1005 349 1263 421">Oven not heating (Upper Oven)</td> </tr> <tr> <td data-bbox="902 421 1005 494">F-19</td> <td data-bbox="1005 421 1263 494">Oven not heating (Lower oven)</td> </tr> </tbody> </table>		CODE	CAUSE	F-9	Oven not heating (Upper Oven)	F-19	Oven not heating (Lower oven)
CODE	CAUSE							
F-9	Oven not heating (Upper Oven)							
F-19	Oven not heating (Lower oven)							
Oven will not work	<ul style="list-style-type: none"> • Plug on range is not completely inserted in the electrical outlet. <ul style="list-style-type: none"> - Make sure electrical plug is plugged into a live, properly grounded outlet. • A fuse in your home may be blown or the circuit breaker tripped. <ul style="list-style-type: none"> - Replace the fuse or reset the circuit breaker. • Oven controls improperly set. <ul style="list-style-type: none"> - See the Using the Oven section. • Oven too hot. <ul style="list-style-type: none"> - Allow the oven to cool to below locking temperature. 							
Arcing or Sparking (Upper Oven)	<ul style="list-style-type: none"> • Cookware is not microwave safe. When in doubt, test cookware before use. • Do not operate oven while empty. 							
Unevenly Cooked Foods (Upper Oven)	<ul style="list-style-type: none"> • Test cookware to make sure it is microwave safe. • Do not cook without the glass tray. • Turn or stir food while cooking. • Defrost food completely before cooking. • Use correct cook time and power level. 							
Overcooked Foods (Upper Oven)	<ul style="list-style-type: none"> • Change cook time or power level. 							
Undercooked Foods (Upper Oven)	<ul style="list-style-type: none"> • Test that cookware is microwave safe. • Defrost food completely before cooking. • Change cook time or power level. • Make sure ventilation ports are not blocked. 							
Improper Defrosting (Upper Oven)	<ul style="list-style-type: none"> • Test that cookware is microwave safe. • Change defrost time or weight. • Turn or stir food during defrost cycle. 							
If the display shows a time counting down but the oven is not cooking	<ul style="list-style-type: none"> • Check that door is firmly closed. • Check that timer wasn't started instead of a cooking function. 							
Steam is exhausted through the oven vent	<ul style="list-style-type: none"> • Cooking foods with high moisture produces steam. This is normal. 							

Symptoms	Possible Causes / Solutions
Appliance does not operate	<ul style="list-style-type: none"> • Make sure cord is plugged correctly into outlet. Check circuit breakers. • Service wiring is not complete. Contact your electrician for assistance. • Power outage. Check house lights to be sure. Call your local electric company for service.
Oven light does not work	<ul style="list-style-type: none"> • Replace or tighten bulb. See Changing the Oven Light section in this Owner's Manual.
Oven smokes excessively during broiling	<ul style="list-style-type: none"> • Control not set properly. Follow instructions under Setting Oven Controls. • Meat too close to the element. Reposition the rack to provide proper clearance between the meat and the element. Preheat broil element for searing. • Meat not properly prepared. Remove excess fat from meat. Cut remaining fatty edges to prevent curling. • Insert on broiler pan wrong side up and grease not draining. Always place grid on the broiler pan with ribs up and slots down to allow grease to drip into pan. • Grease has built up on oven surfaces. Regular cleaning is necessary when broiling frequently. <ul style="list-style-type: none"> - Old grease or food spatters cause excessive smoking.
Food does not bake or roast properly	<ul style="list-style-type: none"> • Oven controls improperly set. <ul style="list-style-type: none"> - See the Using the Oven section. • Rack position is incorrect or the rack is not level. <ul style="list-style-type: none"> - See the Using the Oven section. • Incorrect cookware or cookware of improper size being used. <ul style="list-style-type: none"> - See the Using the Oven section. • Oven sensor needs to be adjusted. <ul style="list-style-type: none"> - See Oven Temperature Adjustment in the Features section.
Food does not broil properly	<ul style="list-style-type: none"> • Oven controls improperly set. <ul style="list-style-type: none"> - Make sure you touch Broil. • Improper rack position being used. <ul style="list-style-type: none"> - See the Broiling Guide. • Cookware not suited for broiling. <ul style="list-style-type: none"> - Use broiling pan and grid. • Aluminum foil used on the broiling pan and grid has not been fitted properly and slit as recommended. <ul style="list-style-type: none"> - See the Using the Oven section. • In some areas the power voltage may be low. <ul style="list-style-type: none"> - Preheat the broil element for 5-7 minutes. - See the Broiling Guide.
Oven temperature too hot or too cold	<ul style="list-style-type: none"> • Oven sensor needs to be adjusted. <ul style="list-style-type: none"> - See Oven Temperature Adjustment in the Features section.

Symptoms	Possible Causes / Solutions
Oven will not Self Clean	<ul style="list-style-type: none"> • The oven temperature is too high to set a Self Clean operation. <ul style="list-style-type: none"> - Allow the oven to cool and reset the controls. • Oven controls improperly set. <ul style="list-style-type: none"> - See the Self Clean section. • A Self Clean cycle cannot be started if the oven lockout feature is active. • Make sure to slide the tank into the slot until it clicks into place.
“Crackling” or “popping” sound	<ul style="list-style-type: none"> • This is the sound of the metal heating and cooling during both the cooking and Self Clean functions. <ul style="list-style-type: none"> - This is normal.
Fan noise	<ul style="list-style-type: none"> • A convection fan may automatically turn on and off. <ul style="list-style-type: none"> - This is normal.
Convection Fan stops	<ul style="list-style-type: none"> • Convection fan stops during a convection bake cycle. <ul style="list-style-type: none"> - This is normal and is done to allow for more even heating during the cycle. This is not a failure of the oven and should be considered normal operation.
Displayed Time is flashing	<ul style="list-style-type: none"> • This is normal. This means that the product has just been plugged in, or that it has experienced a power interruption. Touch the Clock key and reset the time, or touch any key to stop the flashing.
Excessive smoking during a Self Clean cycle	<ul style="list-style-type: none"> • Excessive soil. <ul style="list-style-type: none"> - Set both Oven Mode knobs to the OFF position or press the STOP button. Open the windows to rid the room of smoke. Wait until the Self Clean mode is cancelled. Wipe up the excess soil and restart the Self Clean cycle.
Oven door does not open after a Self Clean cycle	<ul style="list-style-type: none"> • Oven is too hot. <ul style="list-style-type: none"> - Allow the oven to cool below locking temperature. • Allow about one hour for the oven to cool after the completion of a Self Clean cycle. The door can be opened when the lock  is no longer displayed. • The control and door may be locked.
The oven does not clean after a Self Clean cycle	<ul style="list-style-type: none"> • Oven controls not properly set. <ul style="list-style-type: none"> - See the Self Clean section. • Oven was heavily soiled. <ul style="list-style-type: none"> - Clean up heavy spillovers before starting the clean cycle. Heavily soiled ovens may need to Self Clean again or for a longer period of time.
LOCKED is on in the display when you want to cook	<ul style="list-style-type: none"> • The oven door is locked because the temperature inside the oven has not dropped below the locking temperature. <ul style="list-style-type: none"> - Press the STOP button. Allow the oven to cool.
Burning or oily odor emitting from the vent	<ul style="list-style-type: none"> • This is normal in a new oven and will disappear in time. <ul style="list-style-type: none"> - To speed the process, set a Self Clean cycle for a minimum of 3 hours. See the Self Clean section.
Oven racks are difficult to slide	<ul style="list-style-type: none"> • The shiny, silver-colored racks were cleaned in a Self Clean cycle. <ul style="list-style-type: none"> - Apply a small amount of vegetable oil to a paper towel and wipe the edges of the oven racks with the paper towel.

Symptoms	Possible Causes / Solutions
Moisture collects on oven window or steam comes from oven vent	<ul style="list-style-type: none"> • This is normal when cooking foods high in moisture. • Excessive moisture was used when cleaning the window.
Oven will not Steam cook	<ul style="list-style-type: none"> • Make sure to slide the tank into the slot until it clicks into place. • The drain in the water tank may be clogged with hard water scale. If this happens, the descaling function must be run before the steam function can be used.
Water pools in the bottom of the oven during or after steam cooking	<ul style="list-style-type: none"> • During steam cooking, the water in the water tank is transferred to the bottom of the oven. It is normal for water to fill the bottom of the oven during or after the Steam mode. • If the water leaves mineral deposits on the oven bottom, remove the deposits with a cloth or sponge soaked in vinegar.
White residue appears on the oven bottom after steam cooking	<ul style="list-style-type: none"> • Using hard water in the water tank can result in hard water scale on the oven bottom. • To remove mineral deposits that remain on the oven bottom, use a cloth or sponge soaked in vinegar or a weak citric acid solution.
Trouble connecting appliance and smartphone to Wi-Fi network	<ul style="list-style-type: none"> • The password for the Wi-Fi network was entered incorrectly. <ul style="list-style-type: none"> - Delete your home Wi-Fi network and begin the registration process again. • Mobile data for your smartphone is turned on. <ul style="list-style-type: none"> - Turn off the Mobile data on your smartphone before registering the appliance. • The wireless network name (SSID) is set incorrectly. <ul style="list-style-type: none"> - The wireless network name (SSID) should be a combination of English letters and numbers. (Do not use special characters.) • The router frequency is not 2.4 GHz. <ul style="list-style-type: none"> - Only a 2.4 GHz router frequency is supported. Set the wireless router to 2.4 GHz and connect the appliance to the wireless router. To check the router frequency, check with your Internet service provider or the router manufacturer. • The distance between the appliance and the router is too far. <ul style="list-style-type: none"> - If the appliance is too far from the router, the signal may be weak and the connection may not be configured correctly. Move the router closer to the appliance or purchase and install a Wi-Fi repeater.

WARRANTY (USA)

Should your **SIGNATURE KITCHEN SUITE** Oven ("Product") fail due to a defect in materials or workmanship under normal and proper use, during the warranty period set forth below, **SIGNATURE KITCHEN SUITE** will, at its option, repair or replace the Product. This limited warranty is valid only to the original retail purchaser of the Product and applies only when purchased lawfully and used within the United States including U.S. Territories.

WARRANTY PERIOD	SCOPE OF WARRANTY	HOW SERVICE IS HANDLED
Three (3) years from date of original retail purchase	Parts and Labor (internal / functional parts only)	SIGNATURE KITCHEN SUITE will provide, free of charge , all labor and in-home service to replace defective part(s).

- Replacement Products and parts are warranted for the remaining portion of the original warranty period or ninety (90) days, whichever is greater.
- Replacement Products and parts may be new, reconditioned, refurbished, or otherwise factory remanufactured.
- Replaced Product or part(s) will be the property of **SIGNATURE KITCHEN SUITE**.
- Proof of original retail purchase specifying the Product model and date of purchase is required to obtain warranty service under this limited warranty.

EXCEPT TO THE EXTENT PROHIBITED BY APPLICABLE LAW, ANY IMPLIED WARRANTY OF MERCHANTABILITY OR FITNESS FOR A PARTICULAR PURPOSE ON THE PRODUCT IS LIMITED IN DURATION TO THE DURATION OF THE ABOVE LIMITED WARRANTY. UNDER NO CIRCUMSTANCES SHALL SIGNATURE KITCHEN SUITE OR ITS U.S. DISTRIBUTORS/DEALERS BE LIABLE FOR ANY INDIRECT, INCIDENTAL, CONSEQUENTIAL, SPECIAL, OR PUNITIVE DAMAGES, INCLUDING, WITHOUT LIMITATION, LOST GOODWILL, LOST REVENUES OR PROFITS, WORK STOPPAGE, IMPAIRMENT OF OTHER GOODS, COST OF REMOVAL AND REINSTALLATION OF THE PRODUCT, LOSS OF USE, OR ANY OTHER DAMAGES WHETHER BASED IN CONTRACT, TORT, OR OTHERWISE. SIGNATURE KITCHEN SUITE'S TOTAL LIABILITY, IF ANY, SHALL NOT EXCEED THE PURCHASE PRICE PAID BY YOU FOR THE PRODUCT.

SOME STATES DO NOT ALLOW THE EXCLUSION OR LIMITATION OF INCIDENTAL OR CONSEQUENTIAL DAMAGES OR LIMITATIONS ON HOW LONG AN IMPLIED WARRANTY LASTS, SO THE ABOVE EXCLUSIONS OR LIMITATIONS MAY NOT APPLY TO YOU. THIS LIMITED WARRANTY GIVES YOU SPECIFIC LEGAL RIGHTS AND YOU MAY ALSO HAVE OTHER RIGHTS THAT VARY FROM STATE TO STATE.

THIS LIMITED WARRANTY DOES NOT APPLY TO:

- Service trips to deliver, pick up, or install, educate how to operate, correct wiring, or correct unauthorized repairs.
- Damage or failure of the Product to perform during power failures and interrupted or inadequate electrical service.
- Damage or failure caused by leaky or broken water pipes, frozen water pipes, restricted drain lines, inadequate or interrupted water supply or inadequate supply of air.
- Damage resulting from operating the product in a corrosive atmosphere or contrary to the product owner's manual.
- Damage or failure to the Product caused by accidents, pests and vermin, lightning, wind, fire, floods, acts of God, or any other causes beyond the control of **SIGNATURE KITCHEN SUITE**.
- Damage or failure of the Product caused by unauthorized modification or alteration, or if the Product is used for other than the intended purpose, or any water leakage where the Product was not properly installed.
- Damage or failure of the Product caused by incorrect electrical current, voltage, or plumbing codes.
- Damage or failure of the Product caused by transportation, storage, and/or handling, including scratches, dents, chips, and/or other damage to the finish of the Product, unless such damage is reported within one (1) week of delivery.

76 WARRANTY

- Damage or failure of the Product resulting from misuse, abuse, improper installation, repair, or maintenance. Improper repair includes the use of parts not authorized by **SIGNATURE KITCHEN SUITE**. Improper installation or maintenance includes installation or maintenance contrary to the Product owner's manual.
- Damage or failure of the Product caused by the use of parts, components, accessories, consumable cleaning products, or any other products or services that were not authorized by **SIGNATURE KITCHEN SUITE**.
- Damage or missing items to any display or open box Product.
- Refurbished Product or any Product sold "As Is", "Where Is", "With all Faults", or similar disclaimer.
- Products with original serial numbers that have been removed, altered, or cannot be readily determined.
- Increases in utility costs and additional utility expenses.
- Any noises associated with normal operation.
- Products used for other than normal and proper household use (e.g., commercial or industrial use) or contrary to the Product owner's manual.
- Costs associated with removal and reinstallation of the Product for repairs, or the removal and reinstallation of the Product if it is installed in an inaccessible location or not installed in accordance with the Product Owner's manual.
- Accessories, removable components, or consumable parts (e.g. Shelves, door bins, drawers, water/air filters, racks, light bulbs, batteries, etc., as applicable), except for internal/functional parts covered under this limited warranty.

This warranty is extended to the original purchaser for products purchased for home use within the U.S.A. In Alaska, the warranty excludes the cost of shipping or service calls to your home. Some states do not allow the exclusion or limitation of incidental or consequential damages, so this exclusion or limitation may not apply to you. This warranty gives you specific legal rights, and you may also have other rights which vary from state to state. To know what your legal rights are, consult your local or state consumer affairs or your state's Attorney General.

CUSTOMER ASSISTANCE INFORMATION:

To Prove Warranty Coverage	Retain your Sales Receipt to prove date of purchase. A copy of your Sales Receipt must be submitted at the time warranty service is provided.
To Obtain the Nearest Authorized Service Center or Sales Dealer, or to Obtain Product, Customer, or Service Assistance	Call 1-855-790-6655 (Phone answered 24 hours - 365 days a year) and choose the appropriate prompt from the menu; or visit our website at: www.signaturekitchensuite.com ; or by mail: SIGNATURE KITCHEN SUITE Customer Service P.O. Box 240007 Huntsville, AL 35813 ATTN: CIC



Customer Information Center

For inquires or comments, call:
1-855-790-6655 USA

Printed in Korea